



WSAN-YSi

10.1 - 22.2

MANUAL

FOR INSTALLATION,
USE AND MAINTENANCE



MOND00012-00

03-2021

Remote On - Off

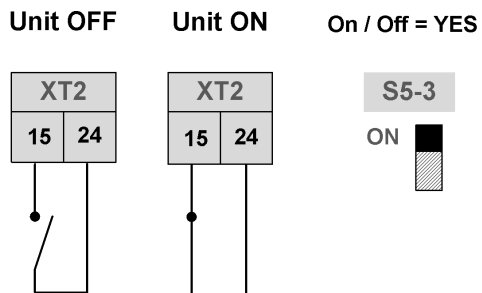

Heat - Cool

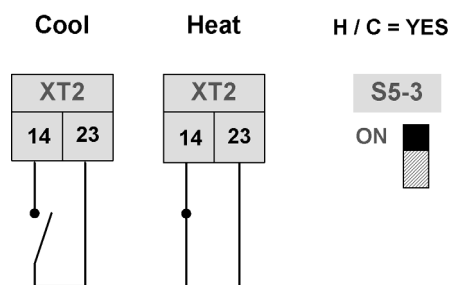

Signals

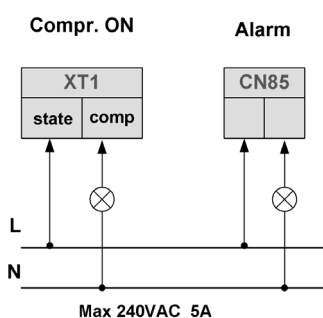

Anti-snow function

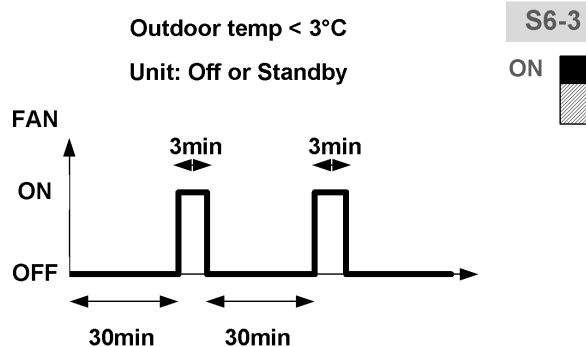

Domestic hot water

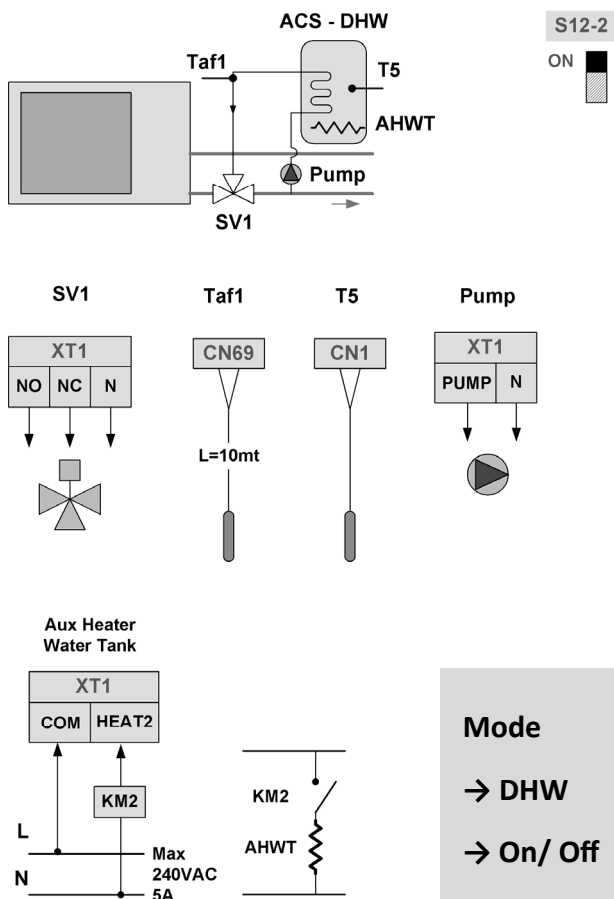

Antifreeze heater

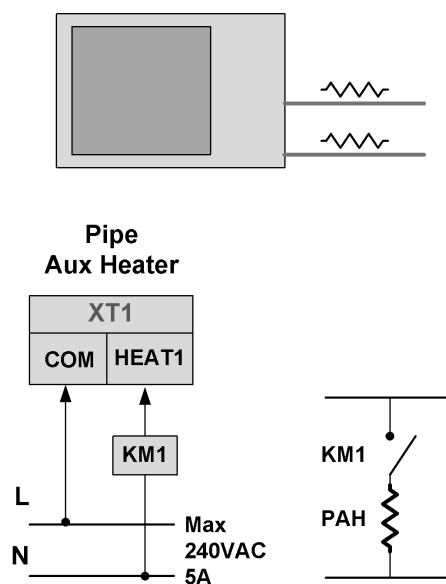

Modular unit

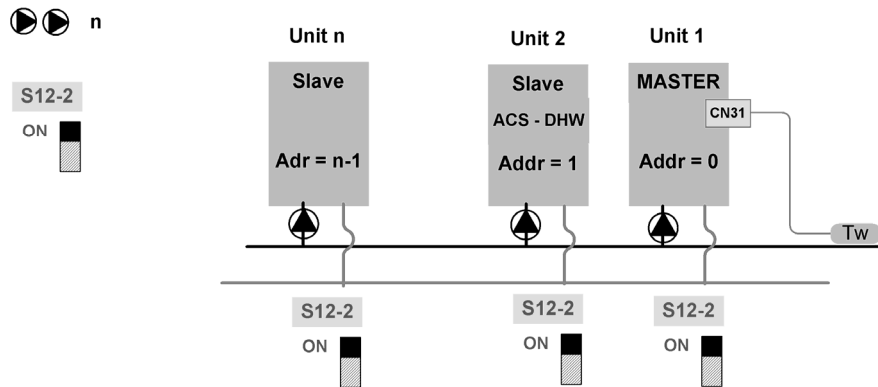
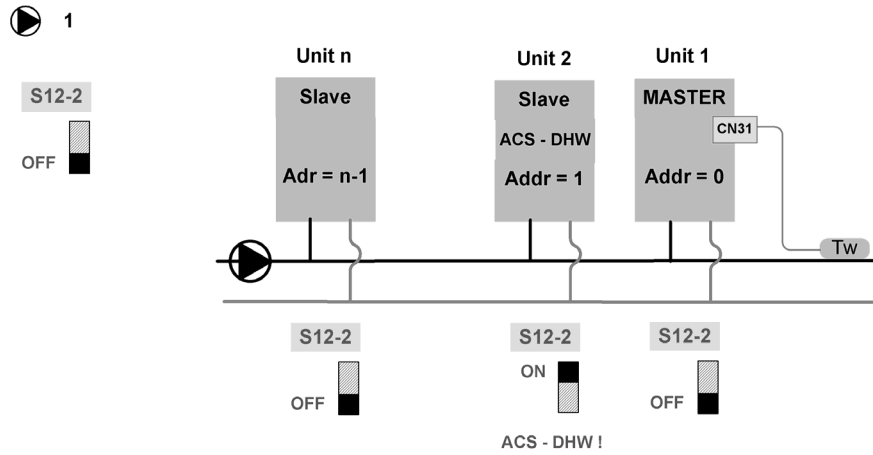

Unit addressing - ENC4

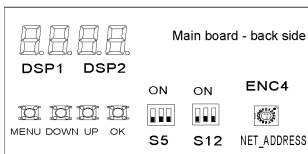

UNIT	1 - MASTER	2 - Slave	3 - Slave	16 - Slave
Addr.	0	1	2	15
ENC4	0	1	2	F

Controller addressing - MENU + ► 3 sec

16 unit max: master unit + 15 slave unit

	UNIT	1 - MASTER	2 - Slave	3 - Slave	16 - Slave
	Addr. controller	0	1	2	15

15 unit max: controller MASTER + 15 unit (1 master + 14 slave)

	UNIT	Controller master	1 - MASTER	2 - Slave	15 - Slave
	Addr. controller	0	1	2	15

Dear Customer,

We congratulate you on choosing these product

Clivet has been working for years to offer systems able to assure the maximum comfort for a long time with highly-reliable, efficient, high-quality and safe solutions. The target of the company is to offer advanced systems, that assure the best comfort and reduce energy consumption as well as the installation and maintenance costs for the entire life-cycle of the system.

With this manual, we want to give you information that are useful for all phases: from reception, installation and use to disposal - so that such an advanced system can provide the best performances during installation and use.

Best regards and have a good read.

CLIVET Spa

The data contained in this manual is not binding and may be changed by the manufacturer without prior notice. Reproduction, even partial, is FORBIDDEN. © Clivet S.p.A. - Feltre (BL) - Italia

1	Safety considerations	7
2	Installation	11
3	Positioning	12
4	Information on refrigerant gas	13
5	Selecting the installation site	14
6	Installation	16
7	Accessing the unit components	19
8	Water connections	21
9	Domestic hot water	28
10	Units in modular configuration	29
11	Electrical connections	31
12	Modbus	39
13	Start-up	44
14	Regulation	52
15	Troubleshooting	66
16	Maintenance	73
17	Disposal	83

White page

The precautions in this manual are divided as indicated on the side.

They are important, so make sure you follow them closely.

Please read these instructions carefully before installing.

Keep this manual handy for future reference.

This unit contains fluorinated gases. For specific information on gas types and quantities, please refer to the plate found on the unit.

Please contact your dealer for future assistance.

DANGER

- ⇒ *An incorrect installation of equipment or accessories may provoke electric shocks, short circuits, leaks, fire or other damages to the equipment. Make sure you only use accessories provided by the supplier - which are designed specifically for the equipment - and make sure they are installed by a professional.*
- ⇒ *All activities described in this manual must be performed by authorised technicians. Make sure to wear suitable personal protection such as gloves and safety goggles while installing the unit or performing maintenance operations.*
- ⇒ *Switch off the power switch before touching electrical components and terminals.*
- ⇒ *When the service panels are removed, the live parts can easily be touched by mistake.*
- ⇒ *Never leave the unit unattended during installation or maintenance operations while the service panel is removed.*
- ⇒ *Do not touch the water pipes during and after performing welding or junction work as the pipes may be very hot and you may burn your hands. To avoid lesions, wait until the pipes return to a normal temperature or make sure you are wearing protective gloves.*
- ⇒ *Do not touch any switch with wet hands. Touching a switch with wet hands may lead to electric shock.*

WARNING

- ⇒ *Maintenance operations must be performed as recommended by the manufacturer. Maintenance and reparation operations requiring the assistance from specialized personnel must be performed under the supervision of the person competent as regards flammable refrigerants.*
- ⇒ *Tear and dispose of plastic bags so that children may not play with them. Children playing with plastic bags risk choking.*
- ⇒ *Some products use PP packaging straps. Do not pull the straps or use them to lift or move the product. It may be dangerous should the straps break.*
- ⇒ *Dispose safely of packaging material such as nails or other metal or wooden parts that may cause lesions.*
- ⇒ *Ask your dealer or qualified personnel to perform installation operations according to this manual. Do not install the unit yourself. An incorrect installation may cause water leaks, electric shock or fire.*
- ⇒ *Make sure to only use accessories and parts specified for installation operations. Failing to use specific parts may cause*

Meaning of the symbols DANGER, WARNING, CAUTION and NOTE

DANGER

- ⇒ *It indicates a situation of imminent danger that, if not avoided, will cause death or serious lesions.*

WARNING

- ⇒ *It indicates a potentially dangerous situation that, if not avoided, may cause death or serious lesions.*

CAUTION

- ⇒ *It indicates a potentially dangerous situation that, if not avoided, may cause slight or moderate injury. Also used to warn against unsafe practices.*

NOTE

- ⇒ *It indicates situation that may cause accidental damage to the equipment or property.*

water leaks, electric shock, fire or the unit falling from its support.

- ⇒ *Install the unit on a structure that can withstand its weight. An insufficiently robust structure may lead to the unit falling causing possible lesions.*
- ⇒ *Perform installation operations considering the possibility that strong winds, hurricanes or earthquakes may occur. Incorrect installation operations may lead to accidents caused by falling equipment.*
- ⇒ *Make sure all electrical operations are performed by qualified personnel in accordance with the law, local regulations and this manual.*
- ⇒ *Connect the unit to a separate power supply circuit. An insufficient capacity of the power supply circuit or incorrect connections may lead to electric shock or fire.*
- ⇒ *Make sure to install an additional differential circuit-breaker against a leakage to earth compliant with the law and local regulations: omnipolar circuit breaker, at least 3 mm separation in all poles, residual current device (RCD) with a rated value not exceeding 30 mA.*
- ⇒ *Failing to install a differential circuit-breaker may lead to electric shock and fire.*
- ⇒ *Make sure all the wiring is safe. Use the specified wires and make sure terminal connections and wires are protected against the water, external forces or other phenomena. Incomplete connections or fixing may cause a fire.*
- ⇒ *When connecting the power supply, arrange the wires so that the front panel can be fixed properly. If the front panel is not in position, it may lead to terminals overheating, electric shock or fire.*
- ⇒ *People working or intervening on a cooling circuit must hold a suitable certification issued by an authorised assessment centre proving their suitability to handle refrigerants safely in compliance with a specific assessment recognised by industry associations.*
- ⇒ *After installation operations are over, verify that there are no refrigerant leaks.*
- ⇒ *Never touch the leaking refrigerant directly, as it may lead to serious frostbite injuries. Do not touch the refrigerant pipes during and right after functioning, as they may be hot or cold depending on the conditions of the refrigerant flowing through the pipes, compressor and other parts of the cooling circuit. Burns or frostbite may occur if you touch the refrigerant pipes. If it is necessary to touch the pipes, wait for them to return to a normal temperature or wear protective gloves and clothes.*
- ⇒ *Do not touch the internal parts (pump, backup heater, etc.) during and immediately after functioning. Touching internal parts may cause burns. To avoid lesions, wait until the internal parts have returned to a normal temperature or, if touching them is necessary, wear protective gloves.*
- ⇒ *Do not use other means than those recommended by the manufacturer to hasten the defrosting or cleaning process.*
- ⇒ *The equipment must be placed somewhere without continuous ignition sources (e.g. open flame, a gas-operated device or an electric heater).*



Warning:
Fire hazard
Flammable materials

- ⇒ Do not pierce nor burn.
- ⇒ Be aware that refrigerants are odourless.
- ⇒ Place the unit on the ground.
- ⇒ The earth resistance should comply with the law and local regulations.
- ⇒ Do not connect the earth cable to gas or water mains, lightning rods or phone earth cables.
- ⇒ Incomplete earthing may cause electrical shocks.
 - Gas mains: fires or explosions may occur in case of a gas leak.
 - Water mains: rigid vinyl tubes are not effective.
 - Lightning rods or phone earth cables: the electrical threshold can increase abnormally if hit by lightning.
- ⇒ Install the power supply cable at least one metre from TVs or radios to prevent interferences or disturbances. Depending on the type of radio wave, one metre may not be enough to avoid disturbances.
- ⇒ Do not wash the unit as it may cause electric shocks or fires.
- ⇒ If the power supply cable is damaged, it must be replaced by the producers, personnel from its assistance network or qualified personnel.
- ⇒ Do not install the unit in the following places:
 - Where there is mineral oil, even in form of vapour. Plastic parts may deteriorate, disperse and cause water leaks.
 - Where corrosive gases (such as sulphurous acid) are produced.
 - Where the corrosion of copper pipes or welded parts may cause refrigerant leaks.
 - Where there are devices emitting electromagnetic waves. Electromagnetic waves may disturb the control system and cause malfunctions.
 - Where flammable gases may leak, or carbon fibre or flammable powers may be found in the air or where volatile flammable materials such as paint thinners or petrol are handled. These gases may cause a fire.
 - Where the air contains high levels of salt, such as the seaside.
 - Where the power supply voltage is subject to fluctuations, such as in factories.
 - On vehicles or ships.
 - Where there are acid or alkaline vapours.
- ⇒ Prior to installation, verify if the user's power supply meets the unit's installation requirements (including reliable earthing, differential circuit-breaker, component size, wire section, etc.). If the electrical installation requirements are not met, the unit cannot be installed until the electrical system is rectified.
- ⇒ Before the hydraulic connection and electrical wiring operations, verify that the installation area is safe and without hidden dangers such as water, electricity and gas conduits.

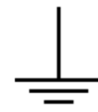

CAUTION

- ⇒ Do not touch the fins of the heat exchanger as they may cause injury.
- ⇒ If installing multiple units in a centralised manner, adjust the electric load on the various phases. Do not connect multiple units to the same phase of the three-phase supply.
- ⇒ The following subjects may use the unit if supervised or instructed on safe usage and capable of understanding the possible dangers: children who are minimum 8 years old, people with no experience or knowledge, people with limited physical, sensory or mental abilities.
- ⇒ Children must not play with the unit.
- ⇒ Cleaning and maintenance operations to be carried out by the user must not be performed by unsupervised children.
- ⇒ Once the installation is complete, the unit tested and functioning is normal, instruct the client as regards the use and maintenance of the unit as indicated in this manual. In addition, make sure that the manual is suitably kept for future reference.
- ⇒ **DISPOSAL:** do not dispose of this product as unsorted waste. Contact the local authorities for information on the collection systems available. If electrical equipment is disposed of in landfills, dangerous substances may infiltrate the waste water and enter the food chain, harming the health and well-being of people and animals.

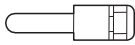
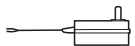

Accessories

Operation and installation manual	1	
Total water probe	1	
Transformer	1	
Wired controller installation manual	1	

Operation conditions of the unit

- 1 The standard power supply voltage is 380-415V 3N~50 Hz, the minimum allowable voltage is 342 V, and the maximum voltage is 456 V.
- 2 To obtain a better performance, use the unit at the following outdoor temperature.

Operating cooling interval

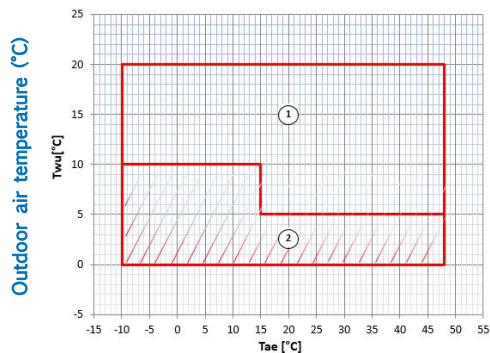

Outlet water temperature (°C)

Twu [°C] = Leaving exchanger water temperature
 Tae [°C] = External exchanger inlet air temperature

- 1 Normal operating range.
- 2 Operating range where the use of ethylene glycol is mandatory in relation to the temperature of the water at the outlet of the user side exchanger.

Operating heating interval

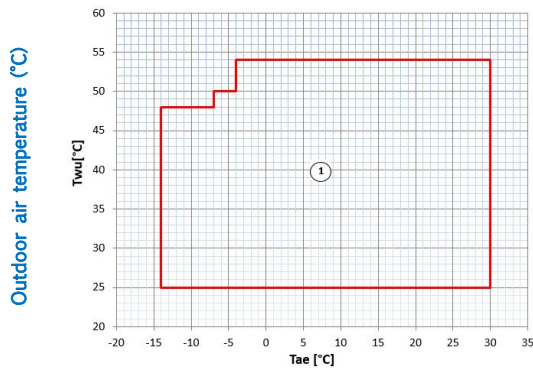

Outlet water temperature (°C)

Domestic hot water operating interval

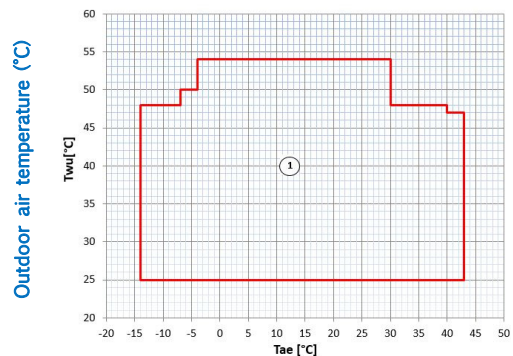

Outlet water temperature (°C)

Twu [°C] = Leaving exchanger water temperature
 Tae [°C] = External exchanger inlet air temperature

- 1 Normal operating range.

Reception

You have to check before accepting the delivery:

- That the unit hasn't been damaged during transport
- That the materials delivered correspond with that indicated on the transport document comparing the data with the identification label positioned on the packaging.

In case of damage or anomaly:

- Immediately make a note of the found damage on the transport document and write the wording: "Accepted subject to checking due to evident shortages/damages due to transport".
- Contact by fax and registered mail with advice of receipt to supplier and the carrier.

NOTE

⇒ Any disputes must be made within 8 days from the delivery. Complaints after this period are invalid.

Storage

Respect the indications on the outside of the pack.

In particular:

- ⇒ minimum ambient temperature -20°C
(possible components damages)
- ⇒ maximum ambient temperature $+45^{\circ}\text{C}$
(possible safety valve opening)
- ⇒ maximum relative humidity 95%
(possible damages to electrical components)

NOTE

⇒ The unit may not be tilted more than 15° during transport.

NOTE

Handling

- 1 Verify unit weight and handling equipment lifting capacity .
- 2 Identify critical points during handling (disconnected routes, ramps, steps, doors).
- 3 Use protections not to damage the unit

Handling by rolling

Place various iron tubes of the same diameter and with a longer length than the width of the unit base.

Lifting.

- Each lifting rope (belt) should be able to bear 4 times the weight of the unit.
- Check the lifting hook of each rope and make sure it is fixed to the unit.
- To avoid damage to the unit, insert a protective block made of wood or of another sturdy material between the unit and the robe; the thickness must be at least 50 mm. (A)
- Before starting handling, make sure that the unit is stable.
- Gradually bring the lifting belts under tension, making sure they are positioned correctly.

DANGER

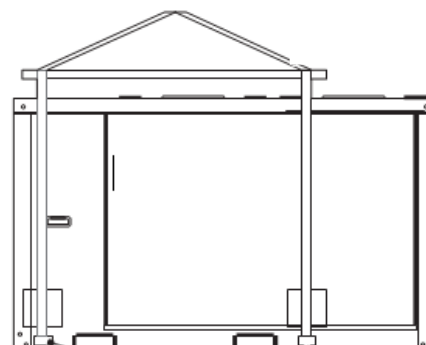
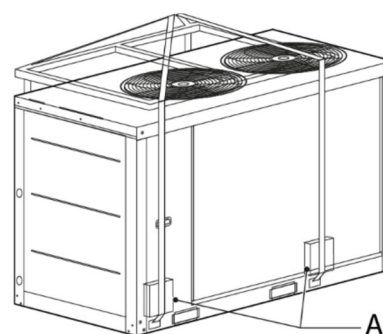

4 INFORMATION ON REFRIGERANT GAS

⇒ *It is strictly forbidden to stand under the machine when it is lifted.*

Removal of packaging

Be careful not to damage the unit.

Recycle and dispose of the packaging material in compliance with local regulations.

4 INFORMATION ON REFRIGERANT GAS

This product contains fluorinated greenhouse gases covered by the Kyoto protocol. Do not discharge gas into air.

Refrigerant type: R32

Characteristics of R32 refrigerant:

- minimum environmental impact thanks to the low Global Warming Potential GWP
- low flammability, class A2L according to ISO 817
- low combustion speed
- low toxicity

The refrigerant quantity is indicated on the unit plate

Quantity factory-loaded refrigerant and equivalent CO₂ tons:

Size	Refrigerant (Kg)	Equivalent CO ²
10.1 - 14.1	7.9	5.33
16.2 - 22.2	14	9.45

Physical characteristics of the R32 refrigerant

Safety class (ISO 817)	A2L	
GWP	675	
LFL Low flammability limit	0.307	kg/m ³ @ 60°C
BV Burning velocity	6,7	cm/s
Punto di ebollizione	-52	°C
GWP	675	100 yr ITH
GWP	677	ARS 100 yr ITH
Self-ignition temperature	648	°C

Positioning

Consider these elements during positioning:

- Technical spaces requested by the unit
- Electrical connections
- Water connections
- Functional clearances

Functional clearances

Functional clearances have the purpose of:

- guaranteeing good unit operation
- allowing maintenance operations
- safeguarding authorised operators and exposed persons.

respecting the functional clearances indicated in the SIZE chapter.

Positioning

Units are designed to be installed:

- OUTDOORS
- in permanent position.

Units may be installed on the ground or on the roof provided that sufficient ventilation is guaranteed.

Warning

⇒ *If the unit is installed on a roof, the roof must be sturdy enough to withstand the weight of the unit and the weight of maintenance personnel.*

Limit the transmission of vibrations:

- use anti-vibration devices or neoprene strips on the unit support points
- install flexible joints on the hydraulic connections

Installation criteria:

- Customer approval
- position accessible safely
- technical spaces requested by the unit
- spaces for the air intake/exhaust
- max. distance allowed by the electrical connections
- install the unit raised from the ground
- verify unit weight and bearing point capacity
- verify that all bearing points are aligned and levelled
- condensate water draining
- consider the maximum possible snow level
- avoid places that can be subject to floods

Protect the unit with a suitable fence in order to avoid access to unauthorised personnel (children, vandals, etc.)

Note

⇒ *A correct circulation of the air is mandatory to guarantee the good unit operating.*

Avoid therefore:

- obstacles to the airflow

5 SELECTING THE INSTALLATION SITE

- ventilation difficulties
- leaves or other foreign bodies that can obstruct the air coil
- winds that hinder or favour airflow
- sources of heat or pollution close to the unit (chimneys, extractors etc..)
- Stratification (cold air that stagnates at the bottom);
- recirculation (expelled air that is sucked in again)
- positioning below ground level, near very high walls, underneath roofs or in corners, which can give rise to stratification or recirculation phenomena.

Note

⇒ *Disregarding the previous indications may affect energy efficiency or lead to blocks due to HIGH PRESSURE (in summer) or LOW PRESSURE (in winter).*

Pressure relief valve gas side

The installer is responsible for evaluating the opportunity of installing drain pipes in compliance with the local regulations in force (EN 378).

If ducted, the valves must be resized according to EN13136.

A	≥ 800	E	≥ 800
B	≥ 2000	F	≥ 1100
C	≥ 2000	G	≥ 6000
D	≥ 800	/	/

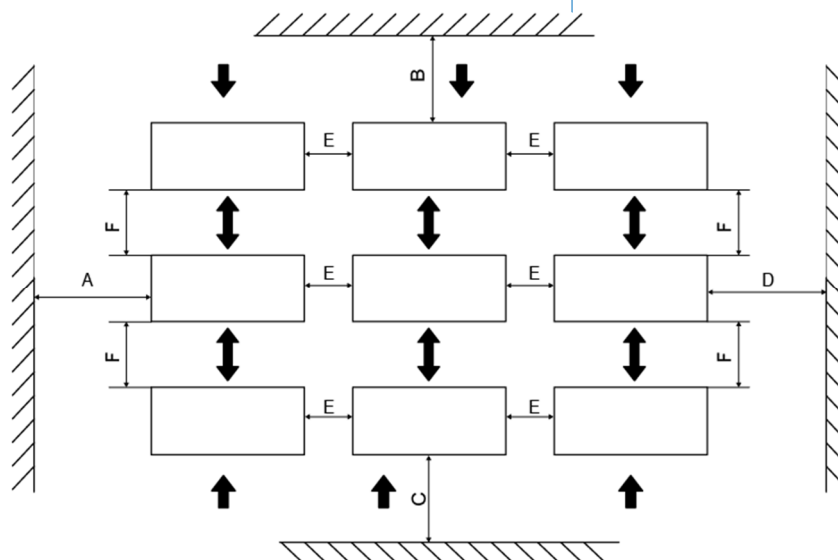
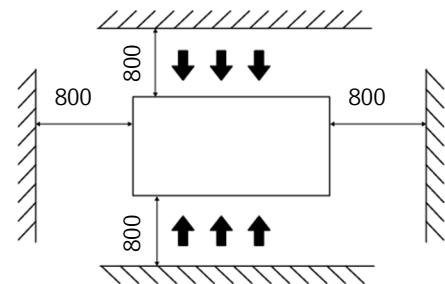
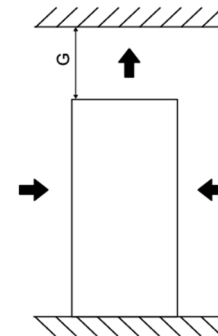

6 INSTALLATION



SIZE 10.1-14.1

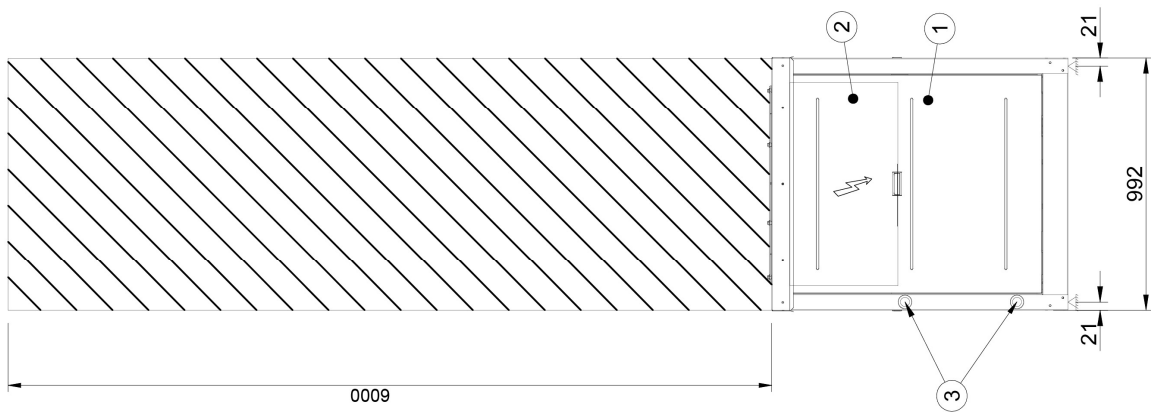
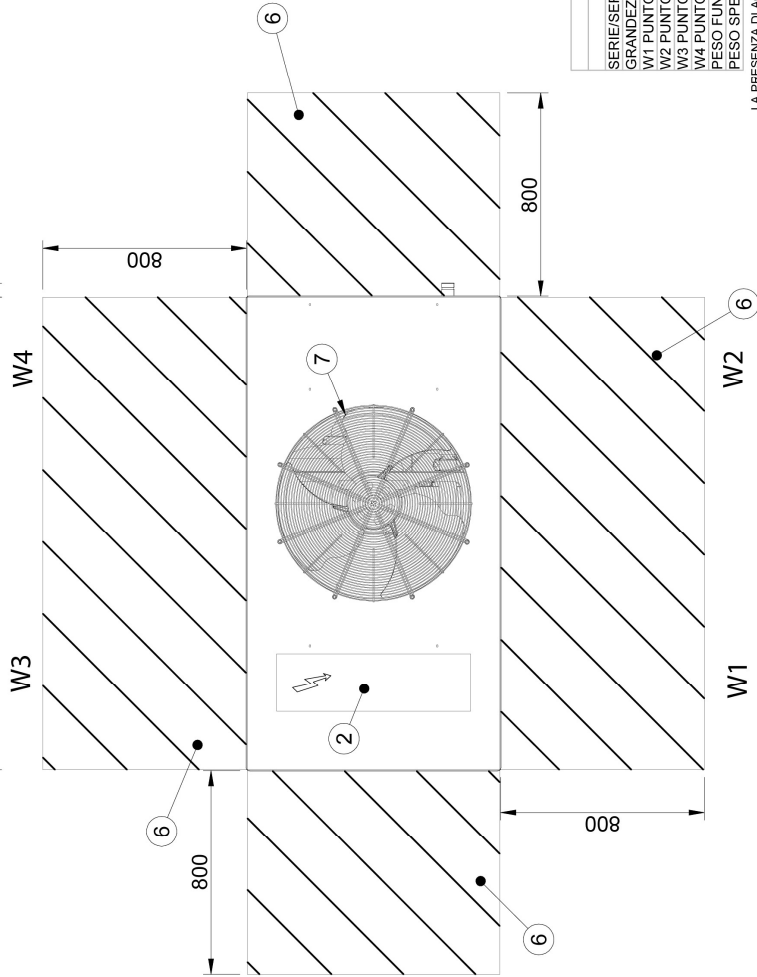
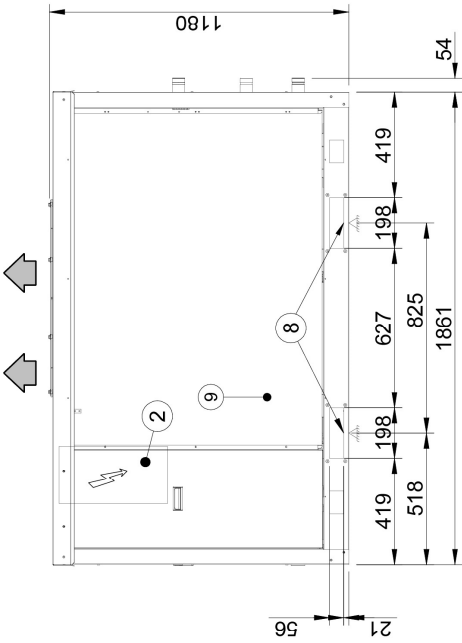
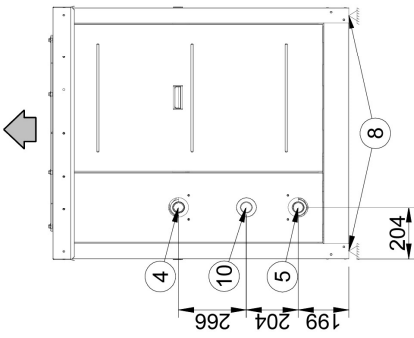

(1)	VANO COMPRESSORI
(2)	COMPRESSOR ENCLOSURE
(3)	QUADRO ELETTRICO
(4)	ELECTRICAL PANEL
(5)	INGRESSO LINEA ELETTRICA
(6)	POWER INPUT
(7)	CONNESSIONE ACQUA IN
(8)	VICTAULIC 1 1/2"
(9)	INLET WATER CONNECTION
(10)	VICTAULIC 1 1/2"
(11)	CONNESSIONE ACQUA OUT
(12)	VICTAULIC 1 1/2"
(13)	OUTLET WATER CONNECTION
(14)	VICTAULIC 1 1/2"
(15)	SPAZI FUNZIONALI
(16)	FUNCTIONAL SPACES
(17)	ELETTROVENTILATORE
(18)	ELECTRIC FAN
(19)	FORI FISSAGGIO UNITA'
(20)	UNIT FIXING HOLES
(21)	SCAMBIATORE ESTERNO
(22)	EXTERNAL EXCHANGER
(23)	USCITA ACS (OPZIONALE)
(24)	VICTAULIC 1 1/2"
(25)	DHW OUTLET (OPTIONAL)
(26)	VICTAULIC 1 1/2"

DISTRIBUZIONE PESI/VERSIONE	
WEIGHT DISTRIBUTION VERSION	
SERIE/SERIES	ND
GRANDEZZA/SIZE	10.1-14.1
W1 PUNTO DI APPOGGIO/SUPPORT POINT	Kg 100
W2 PUNTO DI APPOGGIO/SUPPORT POINT	Kg 62
W3 PUNTO DI APPOGGIO/SUPPORT POINT	Kg 110
W4 PUNTO DI APPOGGIO/SUPPORT POINT	Kg 68
PESO FUNZIONAMENTO/OPERATION WEIGHT	Kg 340
PESO SPEDIZIONE/SHIPPING WEIGHT	Kg 356

LA PRESENZA DI ACCESSORI OPZIONALI PUO' COMPORRE UNA
 PRESSIONE SUI PESI CHE NON SONO RAPPRESENTATI
 NELLA TABELLA. I PESI DEI COMPONENTI E DEI
 ACCESSORI OPZIONALI POTREBBERO RISULTARE IN UNA
 SUBSTANTIAL VARIATION OF THE
 WEIGHT SHOW IN TABLE

6 INSTALLATION



SIZE 16.2-22.2

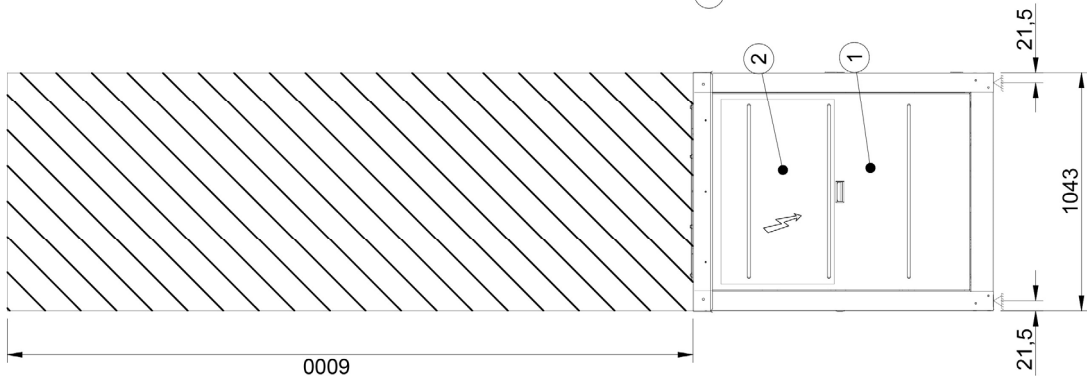
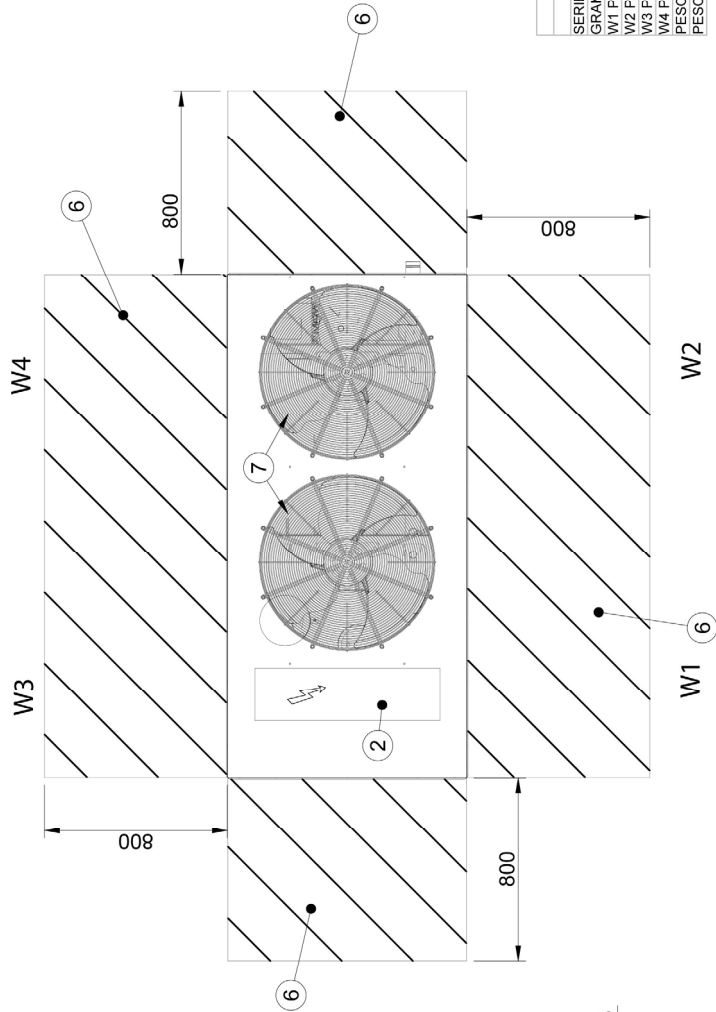
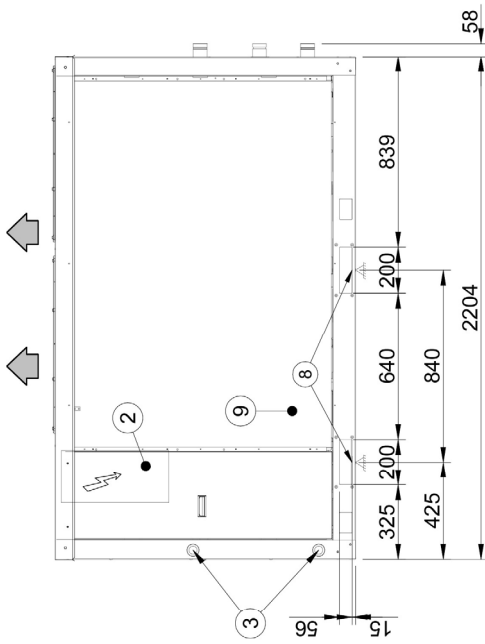
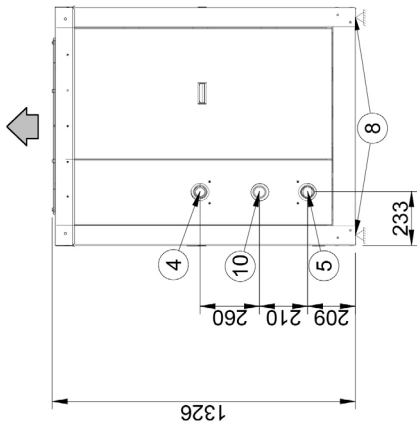

(1)	VANO COMPRESSORI COMPRESSOR ENCLOSURE
(2)	QUADRO ELETTRICO ELECTRICAL PANEL
(3)	INGRESSO LINEA ELETTRICA POWER INPUT
(4)	CONNESSIONE ACQUA IN CITTAULIC 2 [®] INLET WATER CONNECTION VICTAULIC 2 [®]
(5)	CONNESSIONE ACQUA OUT CITTAULIC 2 [®] OUTLET WATER CONNECTION VICTAULIC 2 [®]
(6)	SPAZI FUNZIONALI FUNCTIONAL SPACES
(7)	ELETTROVENTILATORE ELECTRIC FAN
(8)	FORI FISSAGGIO UNITA' UNIT FIXING HOLES
(9)	SCAMBIATORE ESTERNO EXTERNAL EXCHANGER
(10)	USCITA ACS (OPZIONALE) VICTAULIC 2 [®] DHW OUTLET (OPTIONAL) VICTAULIC 2 [®]

DISTRIBUZIONE PESI VERSIONE WEIGHT DISTRIBUTION VERSION	
SERIE/SERIES	ND
GRANDEZZA/SIZE	16.2-22.2
W1 PUNTO DI APPOGGIO/SUPPORT POINT	Kg 155
W2 PUNTO DI APPOGGIO/SUPPORT POINT	Kg 104
W3 PUNTO DI APPOGGIO/SUPPORT POINT	Kg 156
W4 PUNTO DI APPOGGIO/SUPPORT POINT	Kg 105
PESO FUNZIONAMENTO/OPERATION WEIGHT	Kg 520
PESO SPEDIZIONE/SHIPPING WEIGHT	Kg 535

LA PRESENZA DI ACCESSORI OPZIONALI PUO' COMPORRE UNA
VARIAZIONE SIGNIFICATIVA DEI PESI RIPORTATI
OPTIONAL ACCESSORIES MAY RESULT IN A SUBSTANTIAL VARIATION OF THE
WEIGHT SHOW IN TABLE

Structure for installation.

- 1 Both steel and concrete bases may be suitable.
- 2 The base must have a height of at least 300 mm from the ground so as to provide sufficient room to install hydraulic pipes and electrical connections.
- 3 Verify that the base and bearing points are level.
- 4 Envisage a drain for the condensation that may form on the heat exchanger when the unit functions as a heater. The drain must direct the condensation away from roads and pavements, especially in places where condensation might freeze.
- 5 Make sure that the installation base is separate from the buildings, as the noise and vibrations may propagate.
- 6 Fix the unit to the foundation using the installation holes on the base of the unit.

Prevent the accumulation of snow.

Batteries and fans must always be kept free from obstacles, accumulated leaves, snow, etc.

If the unit is installed where it might snow:

- do not install the unit under trees or roofs that may accumulate snow
- envisage a base of a suitable height for a possible accumulation of snow.
- arrange for a roof that can protect the fans from accumulations of snow.
- the roof must not cause short circuits between the air expelled from the fans and that suctioned by the batteries, otherwise the accumulated snow will block the airflow and may cause problems to the equipment.

Installation of the antivibration mounts

Place the antivibration mounts between the unit and the base. Use the holes on the unit frame (15 mm diameter).

NOTE

⇒ If spring antivibration units are also installed, the total height of the unit increases by approximately 135 mm

WARNING

⇒ Use stable and sturdy spacers to maintain the unit lifted and in full safety.

- 1 Make sure the installation base is level.
- 2 Remove the fixing nuts from the antivibration mounts.
- 3 Place the dampeners on the bolts fixing the unit to the ground.
- 4 Lift the unit and align the holes of the fixing bolts with those on the unit base.
- 5 Lower the unit.
- 6 Adjust the operating height and level the unit.
- 7 Tighten the nuts.

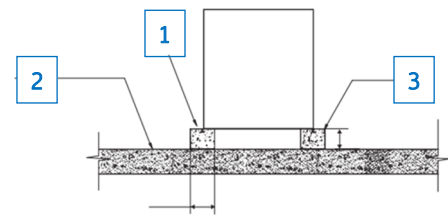

1	Rubber antivibration mounts
2	Solid ground/surface
3	Concrete base $h \geq 200\text{mm}$

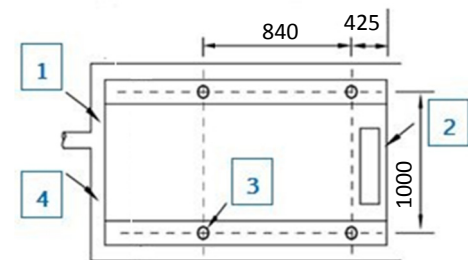
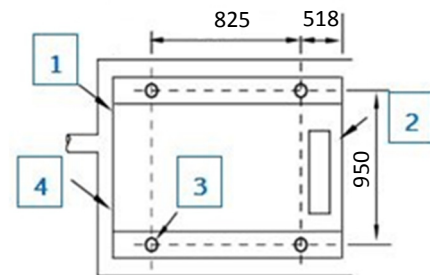

1	Piping inlet/outlet side
2	Electrical panel side
3	Anchoring bolts
4	Condensation drain

7 ACCESSING UNIT COMPONENTS

Access to unit components.

By means of a detachable service panel, the maintenance personnel can easily access the interior components of the unit.

Panel 1

Access to the water pipe and water-side heat exchanger compartment.

Panels 2-3-4

Access to the hydraulic compartment and electrical parts.

Panel 1

Access to water pipe, water-side heat exchanger, accumulator and liquid-vapour separator compartment.

Panels 2-3-4

Access to the hydraulic compartment and electrical parts.

Size 10.1 - 14.1

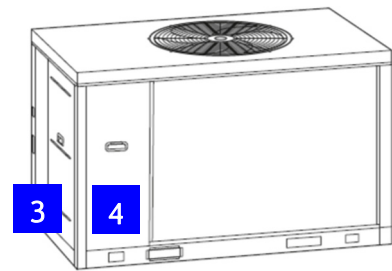
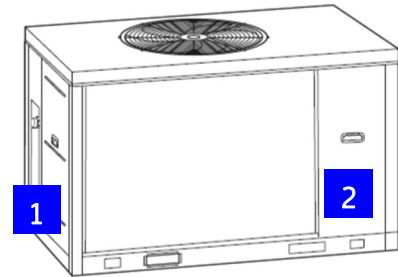

Size 16.2 - 22.2

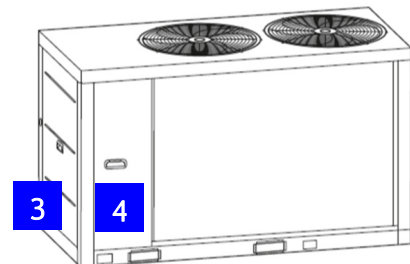
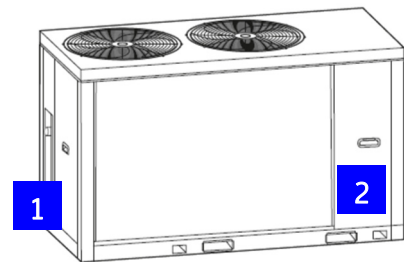

7 ACCESSING UNIT COMPONENTS

Size 10.0 - 14.1

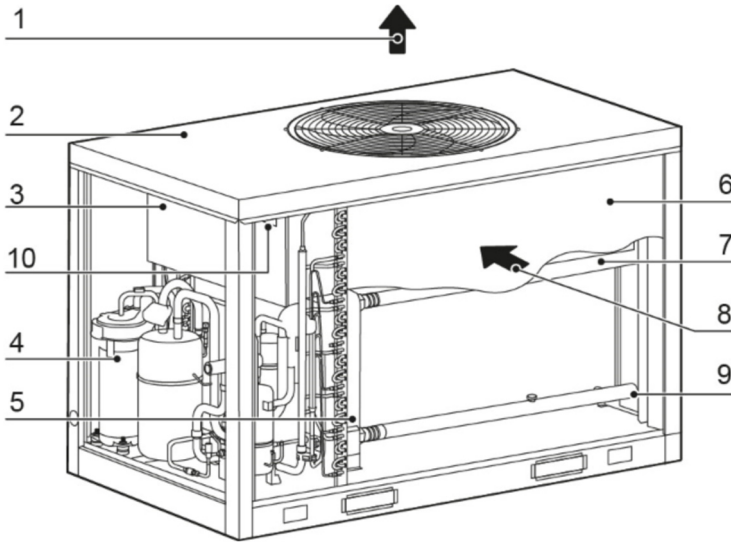

1	Air supply
2	Superior lid
3	Electrical panel
4	Compressor
5	Evaporator
6	Condenser
7	Water inlet
8	Air return
9	Water outlet
10	Controller

Size 16.2 - 22.2

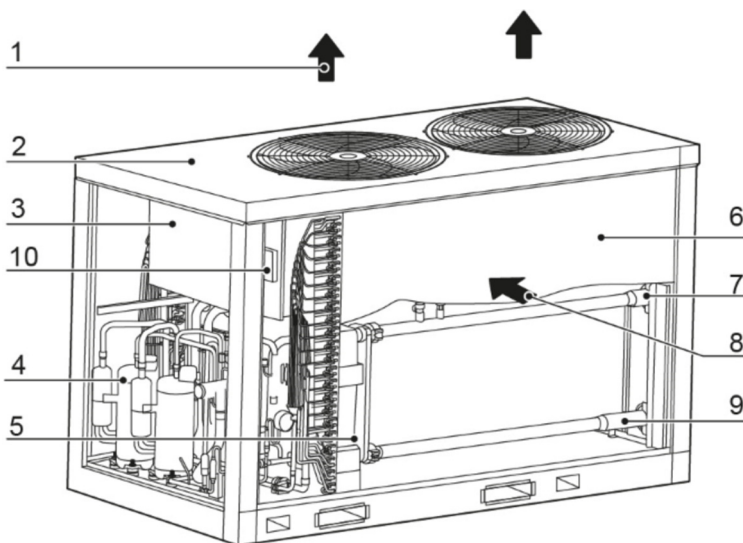

Water quality

Note

⇒ Circulators function well exclusively with clean and high-quality tap water.

The most frequent factors that can affect circulators and the system are oxygen, limescale, sludge, acidity level and other substances (including chlorides and minerals).

In addition to the quality of water, installation also plays an important role. The heating system must be airtight. Choose materials that are not sensitive to oxygen diffusion (risk of corrosion...).

Characteristics of the water

- compliant with local regulations
- Langelier Index (LI) between 0 and +0.4
- within the limits indicated in the chart

Water quality must be checked by qualified personnel.

Hardness

If the water is hard, install a system suitable to preserve the unit from harmful deposits and limestone formation.

If necessary, install a water softener to reduce water hardness

Cleanliness

Before connecting the water to the unit, clean the system thoroughly with specific products effective to remove residues or impurities that may affect functioning. Existing systems must be free from sludge and contaminants and protected against build-ups.

New systems

In case of new installations, it is essential to wash the entire installation (with the circulator uninstalled) before commissioning the central installation. This removes residues of the installation process (welding, waste, joint products...) and preservatives (including mineral oil). The system must then be filled with clean high-quality tap water.

Existing systems

If a new boiler or heat pump is installed on an existing heating system, the system must be rinsed to avoid the presence of particles, sludge and waste. The system must be drained before installing the new unit. Dirt can be removed only with a suitable water flow. Each section must then be washed separately.

Particular attention must also be paid to “blind spots” where a lot of dirt can accumulate due to the reduced water flow. The system must then be filled with clean high-quality tap water. If, after rinsing, the quality of the water is still unsuitable, a few measures must be taken to avoid problems. An option to remove pollutants is to install a filter. Various types of filters are available. A mesh filter is designed to catch large dirt particles. This filter is usually placed in the part with the larger flow. A tissue filter is designed to catch the finer particles.

Water component for corrosion limit on Copper

PH	7.5 ÷ 9.0	
SO ₄ ⁻⁻	< 100	
HCO ₃ ⁻ / SO ₄ ⁻⁻	> 1	
Total Hardness	8 ÷ 15	°f
Cl ⁻	< 50	ppm
PO ₄ ³⁻	< 2.0	ppm
NH ₃	< 0.5	ppm
Free Chlorine	< 0.5	ppm
Fe ₃ ⁺	< 0.5	ppm
Mn ⁺⁺	< 0.05	ppm
CO ₂	< 50	ppm
H ₂ S	< 50	ppb
Temperature	< 65	°C
Oxygen content	< 0.1	ppm
Sand	10 mg/L 0.1 to 0.7mm max diameter	
Ferrite hydroxide Fe ₃ O ₄ (black)	Dose < 7.5 mg/L 50% of mass with diameter < 10 µm	
Iron oxide Fe ₂ O ₃ (red)	Dose < 7.5mg/L Diameter < 1 µm	

Exclusions

The warranty does not cover damage formed by limestone, deposits and impurities deriving from the water supply and/or by the malfunctioning of the system cleaning system.

Risk of frost

Note

⇒ *When the outside temperature gets close to 0°C, the water in the pipes and unit may freeze.*

⇒ *Frost may determine irreversible damage to the unit.*

⇒ *Frost damage is not covered by the warranty.*

If the unit or hydraulic connections are subject to temperatures close to 0°C:

- mix water with glycol, or
- safeguard the pipes with heating cables placed under the insulation, or
- empty the system in cases of long non-use

Anti-freeze solutions

Consider that the use of anti-freeze solution determines an increase in a pressure drop.

Make sure that the glycol type utilized is inhibited (not corrosive) and compatible with the water circuit components.

Do not use different glycol mixture (i.e. ethylene with propylene).

Water filter

Use filter ≥ **30 mesh**

Note

⇒ *It must be installed immediately in the water input of the unit, in a position that is easily accessible for cleaning.*

⇒ *The filter should never be removed, doing so invalidates the warranty.*

Minimum capacity of the exchanger

The minimum water flow is indicated in the technical data. If the system capacity is below the minimum flow, bypass the system as indicated in the diagram.

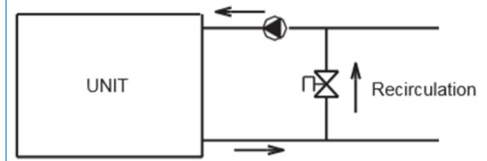

Maximum capacity of the exchanger

The maximum water flow is indicated in the technical data. If the system capacity exceeds the minimum flow, bypass the system as indicated in the diagram.

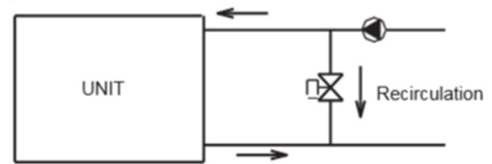

Minimum and maximum water flow

SIZE	Water flow (l/s)	
	Minimum	Maximum
10.1 - 14.1	0.9	2.6
16.2 - 22.2	1.8	5.0

8 HYDRAULIC CONNECTIONS

Standard Unit

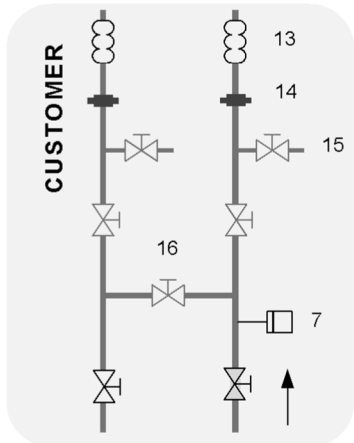
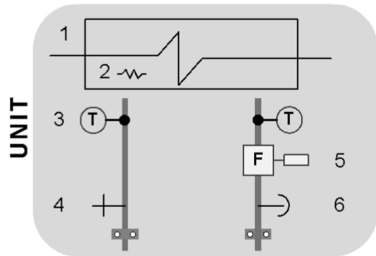

Unit + pump

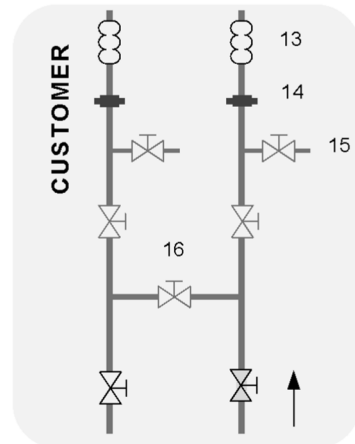
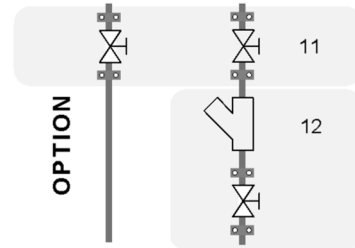
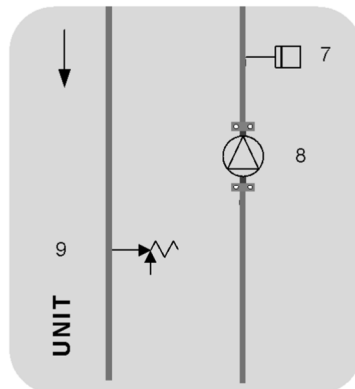
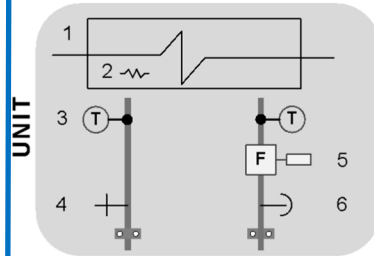

- 1 exchanger
- 2 antifreeze heater
- 3 water temperature probes
- 4 drain
- 5 water flow switch
- 6 vent
- 7 system loading safety pressure switch
- 8 pump
- 9 safety valve
- 10 N.D.
- 11 shut-off valves
- 12 filter
- 13 flexible couplings
- 14 piping supports
- 15 exchanger chemical cleaning bypass
- 16 system cleaning bypass
- 17 N.D.

Unit + storage tank

Unit with storage tank

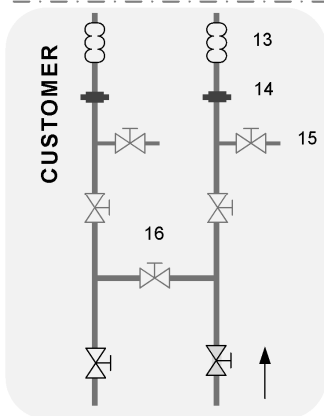
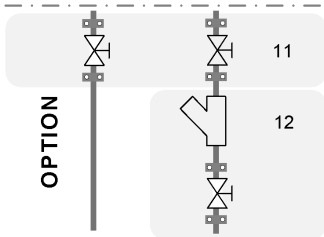
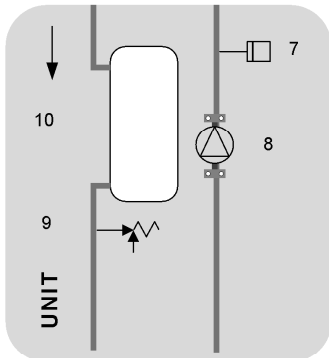
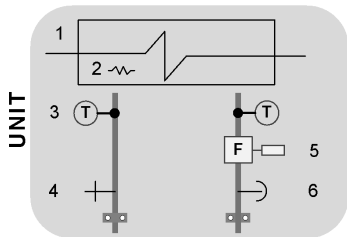

Unit + 3 DHW ways

Unit with storage tank + 3-way valve

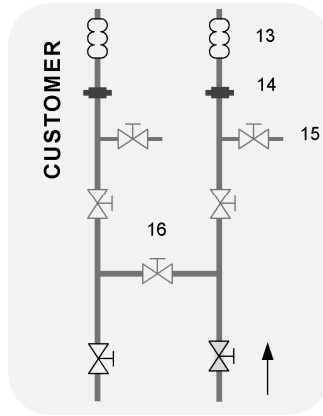
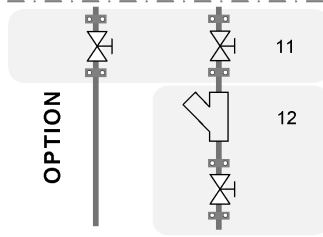
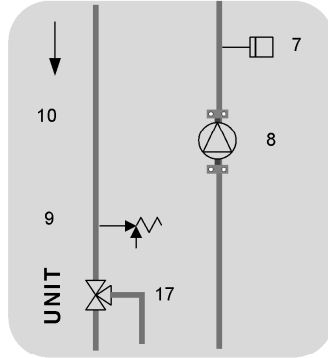
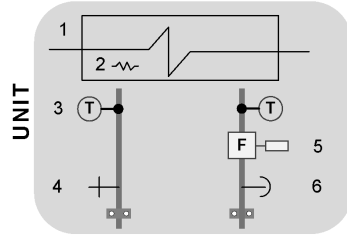

- 1 exchanger
- 2 antifreeze heater
- 3 water temperature probes
- 4 drain
- 5 water flow switch
- 6 vent
- 7 system loading safety pressure switch
- 8 pump
- 9 safety valve
- 10 storage tank
- 11 shut-off valves
- 12 filter
- 13 flexible couplings
- 14 piping supports
- 15 exchanger chemical cleaning bypass
- 16 system cleaning bypass
- 17 domestic hot water valve

8 HYDRAULIC CONNECTIONS

Storage tank

Option

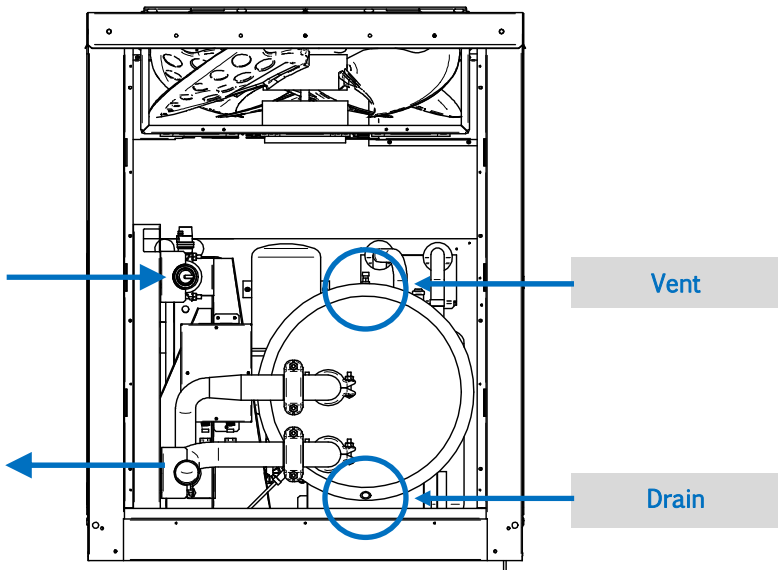

Inverter pump + DHW switching valve

Option

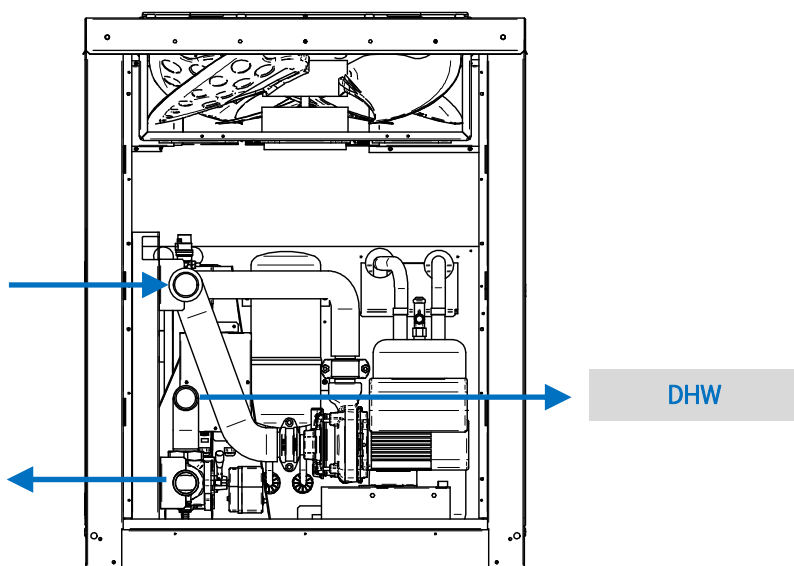

8 HYDRAULIC CONNECTIONS

SIZE 10.1-14.1

Quick coupling Victaulic 1 1/2"

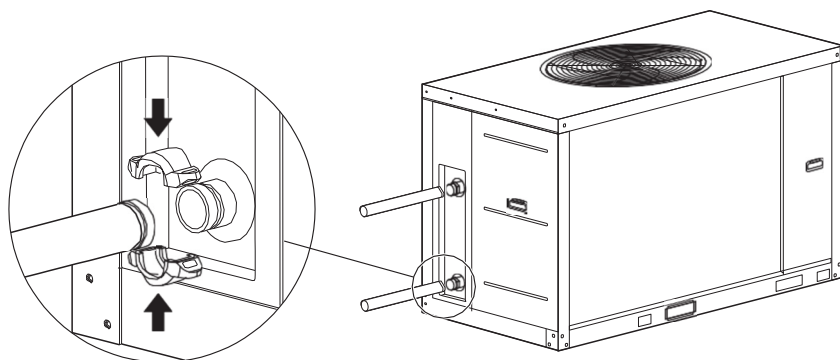

SIZE 16.2-22.2

Quick coupling Victaulic 2"

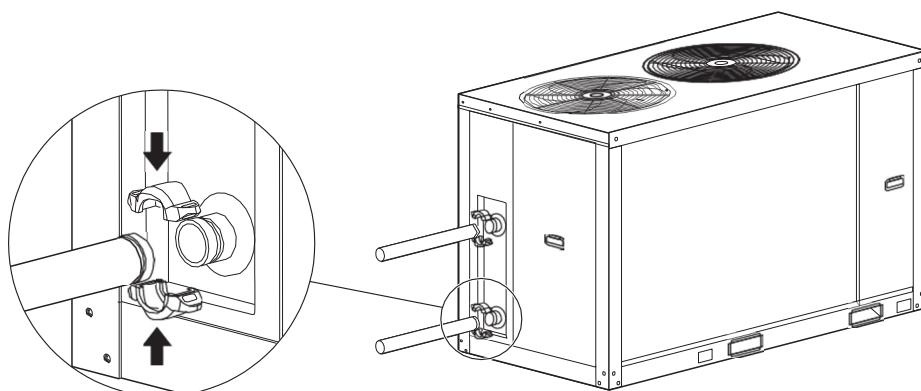

9 DOMESTIC HOT WATER

Option.

Domestic hot water management is of priority compared to the system.

In DHW production mode, the compressors start only if the DHW storage temperature is above a minimum threshold (see chart).

The maximum supply temperature threshold of the system is variable based on the outdoor temperature.

To prevent it from falling below the minimum temperature, it is advisable to install a backup electric heater on the DHW storage (see KM2, SV1, Taf1 on page 31).

Verify that S12-2 is on ON (page 32).

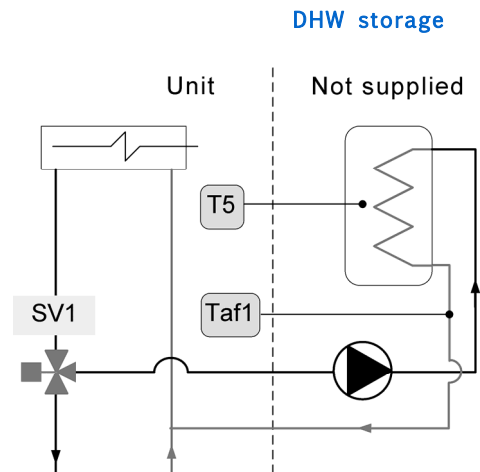

T outdoor	T5 DHW storage tanks	compr.	backup heater
$24^{\circ}\text{C} < t_o \leq 30^{\circ}\text{C}$	$< 15^{\circ}\text{C}$	OFF	ON
$24^{\circ}\text{C} < t_o \leq 30^{\circ}\text{C}$	$\geq 15^{\circ}\text{C}$	ON	OFF
$t_o > 30^{\circ}\text{C}$	$< 20^{\circ}\text{C}$	OFF	ON
$t_o > 30^{\circ}\text{C}$	$\geq 20^{\circ}\text{C}$	ON	OFF

10 MODULAR CONFIGURATION UNITS

Maximum 4 units in the same water branch.

Maximum total 16 units.

The output water temperature regulation probe, flow probe and auxiliary electric heater must be controlled by the master unit.

All units must be electrically connected to each other (see ELECTRICAL CONNECTIONS chapter)

Each module can be equipped with an inertial system storage tank.

Each unit with DHW option must have its own DHW storage tank.

It is not possible to have a hydronic assembly installed on board.

It is necessary to provide an external pumping unit, sized for the entire capacity of the modular system (responsibility of the Customer). The pumping unit will be managed by the Master unit through a potential-free contact and 0-10V signal.

See page 31 for the configuration.

TW probe

It must be installed on the supply of the unit, as far away as possible.

System diagram with inverted return connection

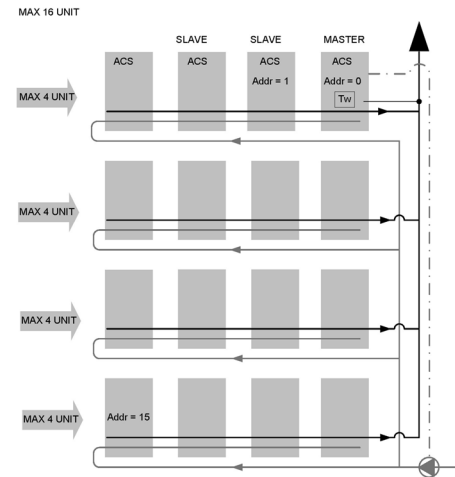

Input and output manifolds

Cooling (Kw) Min Max		Piping water IN-OUT
15	30	DN40
30	90	DN50
90	130	DN65
130	210	DN80
210	325	DN100
325	510	DN125
510	740	DN150
740	1300	DN200
1300	2080	DN250

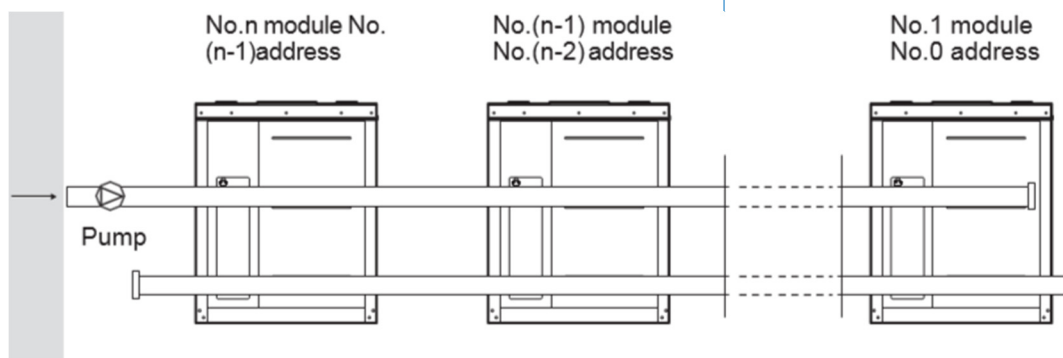

Single/multiple pump system

Set up the DIP S12-2 according to the type of system.

Single water pump

The retaining valve is not necessary with this configuration.

The pump control is only activated on the master unit

Multiple water pumps.

A retaining valve for each unit is necessary with this configuration.

Pump control is activated on each unit.

Operations sequence

Before starting the unit pump :

- 1 close all vents in the high points of the unit's water circuit.
- 2 close all drain shut-off valves in the low points of the unit's water circuit:

- Heat exchangers
- Pumps
- collectors
- storage tank

- 1 Wash the system thoroughly with clean water:
 - use the bypass to exclude the exchanger from the flow (diagram on the previous page)
 - fill and empty the system multiple times.
- 2 Apply additives to prevent corrosion, fouling, formation of mud and algae.
- 3 Fill the system
 - Do not use the unit pump.
- 4 Conduct a leak test.
- 5 Isolate the pipes to avoid heat dispersions and formation of condensate.
 - Leave various service points free (wells, vents, etc).

Note

⇒ *Neglecting to wash will lead to the filter having to be cleaned many times and at worst may damage the exchangers and other parts*

Single water pump

dip S12-2 = OFF

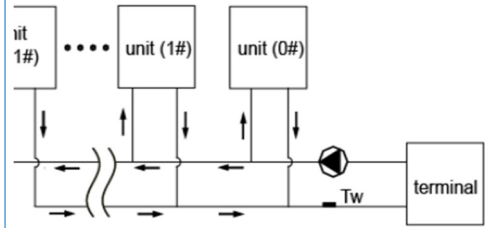

Multiple water pumps.

dip S12-2 = ON

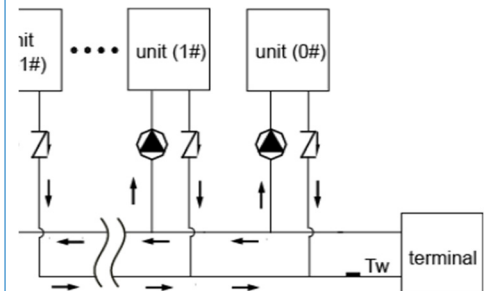

The characteristics of the lines must be determined by specialized personnel able to design electrical installations in compliance with regulations in force.

The protective equipment of the unit supply line must be able to shut-off the presumed short circuit current, which value must be determined in accordance with the system features.

The power cable and protection cable section must be defined in accordance with the characteristics of the protections adopted.

All electrical operations should be performed by trained personnel having the requirements envisaged by the regulations in force and informed about the risks relevant to these activities.

Operate in compliance with safety regulations in force.

Electric data

The serial number label reports the unit's specific electrical data, electrical accessories included.

The electrical data indicated in the technical bulletin and in the manual refer to the standard unit, accessories excluded.

The label reports the indications envisaged by regulations, in particular:

Voltage

F.L.A.: full load ampere, absorbed current at maximum admitted conditions

F.L.I.: full load input, full load power input at max. admissible condition

Electrical wiring diagram No.

Connections

Refer to the unit's electrical diagram (the number of the diagram is shown on the serial number label)

Verify that the electrical supply has characteristics conforming to the data shown on the serial number label.

Before starting work, ensure the unit is isolated, unable to be turned on and a safety sign used.

Ensure correct earth connection.

Ensure cables are suitably protected.

Before powering the unit, make sure that all the protections that were removed during the electrical connection work have been restored.

Electric line input

Fix the cables: if vacated, they may be subject to tearing. The cables must not touch the compressor and the refrigerant piping (they reach high temperatures).

Use eyelet wire terminals.

If the length of the cable exceeds the value specified in the chart or if the voltage drop exceeds the threshold, increase the section of the power supply cable in compliance with relevant regulation.

The lightning rod and unit earthing cables must be separate.

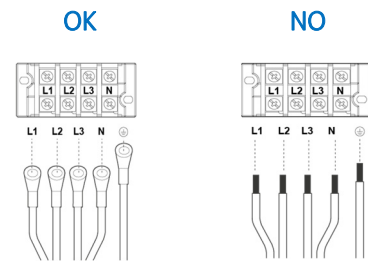

Sizes	Remote ON - OFF External power supply			
	Power supply	Switch manual	fuses	Wiring (Lmax = 20 mt)
10.1 - 14.1	380-415V 3N~ 50Hz	50A	36A	10mm ² X 5
16.2 - 22.2	380-415V 3N~ 50Hz	100A	63A	16mm ² X 5

Remote ON - OFF

To enable the remote On-Off, set DIP switch S5-3 on ON.

With the units in modular configuration, remote control must be applied to the master unit, which transmits it to the slave units. After setting up the S5-3, interrupt and reconnect the voltage to activate the modification.

This way, the controller function is disabled.

Connect the remote control to inlet: XT2 15 - 24

Do not perform short On-Off cycles

Do not use the remote On-Off with a thermoregulation function.

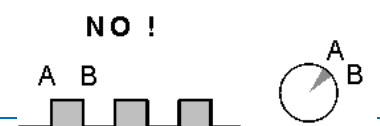
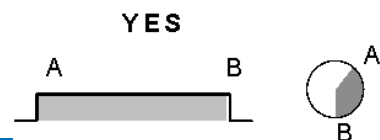
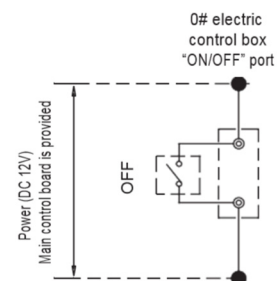

Remote Heat Cool

To enable the remote Heat-Cool, set DIP switch S5-3 on ON.
 With the units in modular configuration, remote control must be applied to the master unit, which transmits it to the slave units.
 After setting up the S5-3, interrupt and reconnect the voltage to activate the modification.

This way, the controller function is disabled.

Connect the remote control to inlet: XT2 14 - 23

Flow switch - SW WATER

Factory wiring

Double setpoint - SW TEMP

Refer to page 30 to enable the function.

Keypad remote connections

The keypad is wired on the unit.

It can be disassembled and installed remotely.

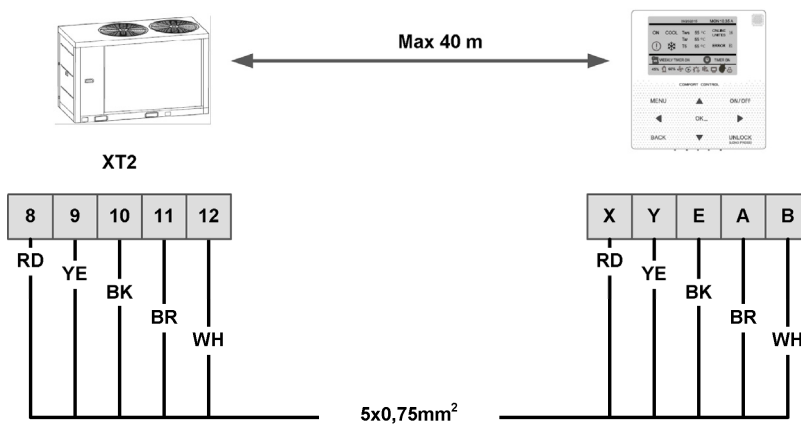

Maximum distance 40 m.
 Power supplied by the unit.

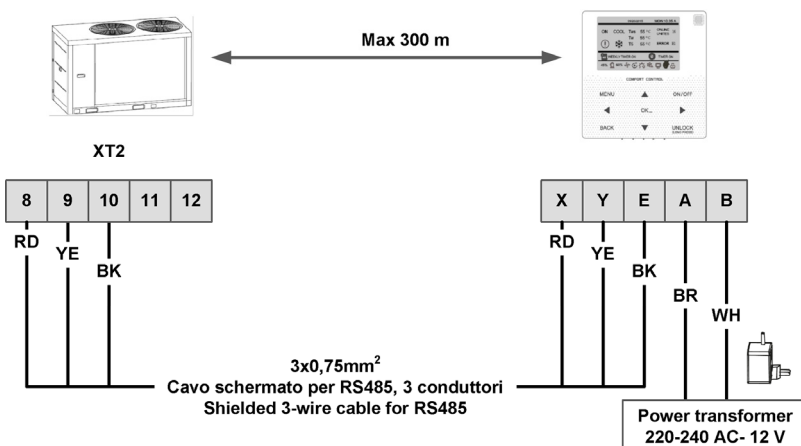

Maximum distance 300 m.
 Separate power supply
 Power supply provided with the unit.

Alarm signal - ALARM

The door is closed with alarmed unit.

The door is open with the unit functioning normally.

Functioning compressor signal - HL1

Connect the signal lamp as shown in the diagram.

External pump control - PUMP-N

In case of a unit supplied with no circulation pump, control the external pump as shown in the diagram.

Use a contactor.

Auxiliary heater control - KM2

Control the auxiliary heater as shown in the diagram.

Use a contactor.

Anti-freeze heater control - KM1

Control the heater as shown in the diagram.

Use a contactor.

Domestic hot water

The following components are required:

- 3-way valve SV1
- temperature probe Taf1
antifreeze protection for domestic hot water
- temperature probe T5
regulation and switching between comfort and hot water production

Operations sequence:

- 1 disconnect the probe Taf1 supplied and connected as standard on the unit (main board-CN69)
- 2 connect the probe Taf1 supplied as spare part with the 10mt cable (main board-CN69)
- 3 after connecting the cable put the probe on the domestic hot water line
- 4 connect T5 connector and put the T5 probe into the domestic hot water storage

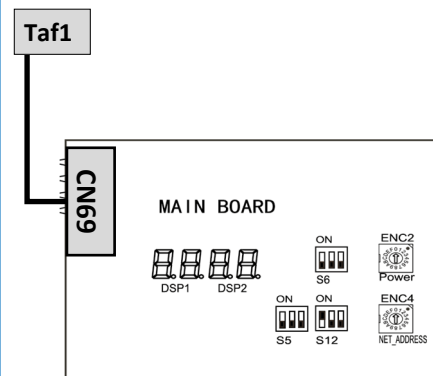
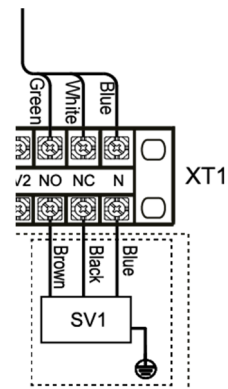
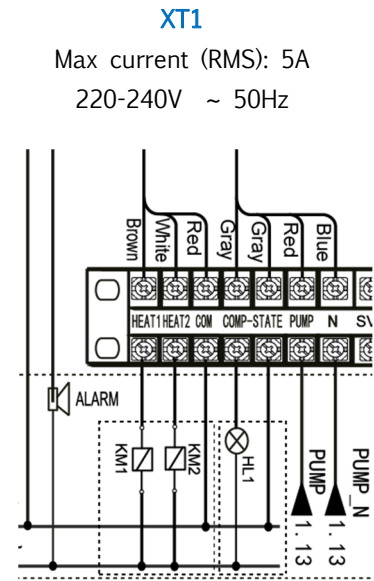
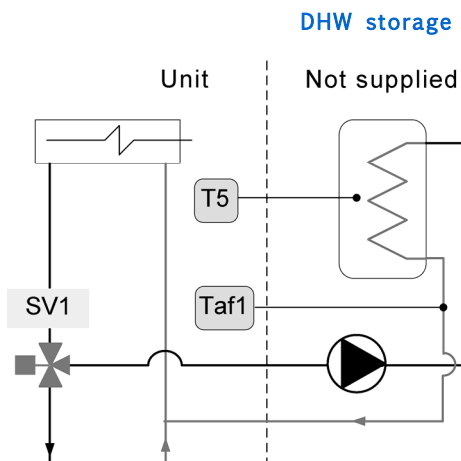

Configurations on the digital display

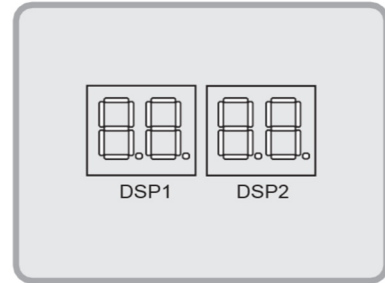
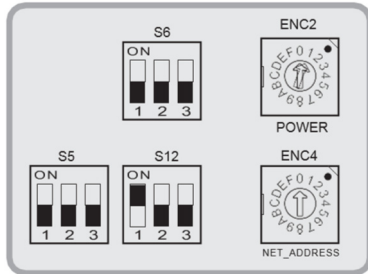

ENC2		0/1	Size = 0 Size = 1
ENC4		0-F	0-F valid to set the unit address on DIP switches 0-F indicates the master unit and 1-F indicates the slave units (modular unit configuration) 0 factory settings
S5-3		OFF	Control of the unit from the display on the machine Valid for S5-3 OFF (factory setting)
		ON	Controlling the unit through remote On-off and remote Heat-Cool inlet Valid for S5-3 ON
S6-3		OFF	Anti-snow function not valid Valid for S6-3 OFF (factory setting)
		ON	Anti-snow function valid Valid for S6-3 ON
S12-1		ON	Valid for S12-1 ON (factory setting)
S12-2		OFF	Control of single water pump Valid for S12-2 OFF (factory setting)
		ON	Control of multiple water pumps Valid for S12-2 ON
S12-3		OFF	Normal cooling mode Valid for S12-3 OFF (factory setting)
		ON	Low-temperature cooling mode Valid for S12-3 ON

MODULAR CONFIGURATION UNITS

Set the correct date and time on each unit before connecting them to the network

Set multiple configuration on each unit:

SW12-2 :

ON multiple configuration unit (or enabling of DHW menu)

OFF single unit

The modular configuration is made up of two networks: the controller network and the unit network (main keypads).

Each network can have max 16 addresses (0 to 15) and must be addressed separately.

Each network has its own master, which must have address = 0.

If some slaves do not have the DHW function:

- set a unit without DHW option as a master.
- assign the higher addresses to slaves with the DHW option.

Unit addressing

Addressing is carried out through encoder ENC4 on the back of the keypad.

The address corresponds to the number on the encoder

The address is shown on the display DSP1.

E.g.:

MASTER : address = 0 encoder = 0

SLAVE 1 : address = 1 encoder = 1

SLAVE 15 : address = 15 encoder = F

The address of the unit is shown on display “DSP1” on the main keypad.

Addressing controls

A maximum of 16 controls can be addressed, with address from 0 to 15; so for example :

- 16 units with relative controller on board, one of which is the master
- 15 units with relative controller on board + a remote controller as the master

Press MENU + ► for 3 seconds

Press ▲ ▼ to select the address

•

Modular unit communication bus

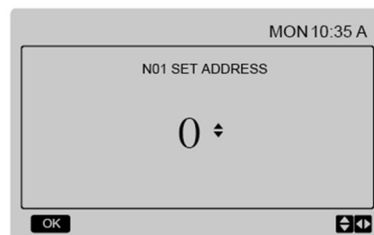
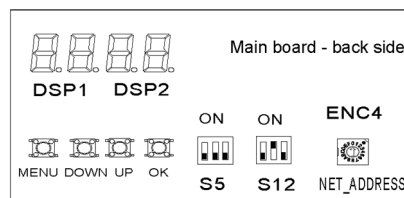
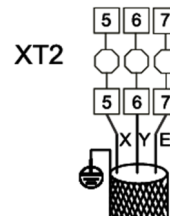

Signal lines

Use shielded cables. Any other cable may produce an interference that will cause malfunctioning of the unit.

The screen must be connected to earth without interferences.

Guarantee the continuity of the screen during the entire extension of the cable.

Do not exceed the maximum distance allowed.

Lay the cables away from the power lines with a different voltage or that emit interferences of electromagnetic origin.

Avoid laying other cables in a parallel manner. Crossing with other cable is only allowed if at 90°.

In case of parallel power supply and signal cables, use separate metal ducts. Minimum distance between power supply and signal cables:

- 300 mm for absorption up to 10A.
- 500 mm for absorption up to 50A.

MODULAR CONFIGURATION UNIT

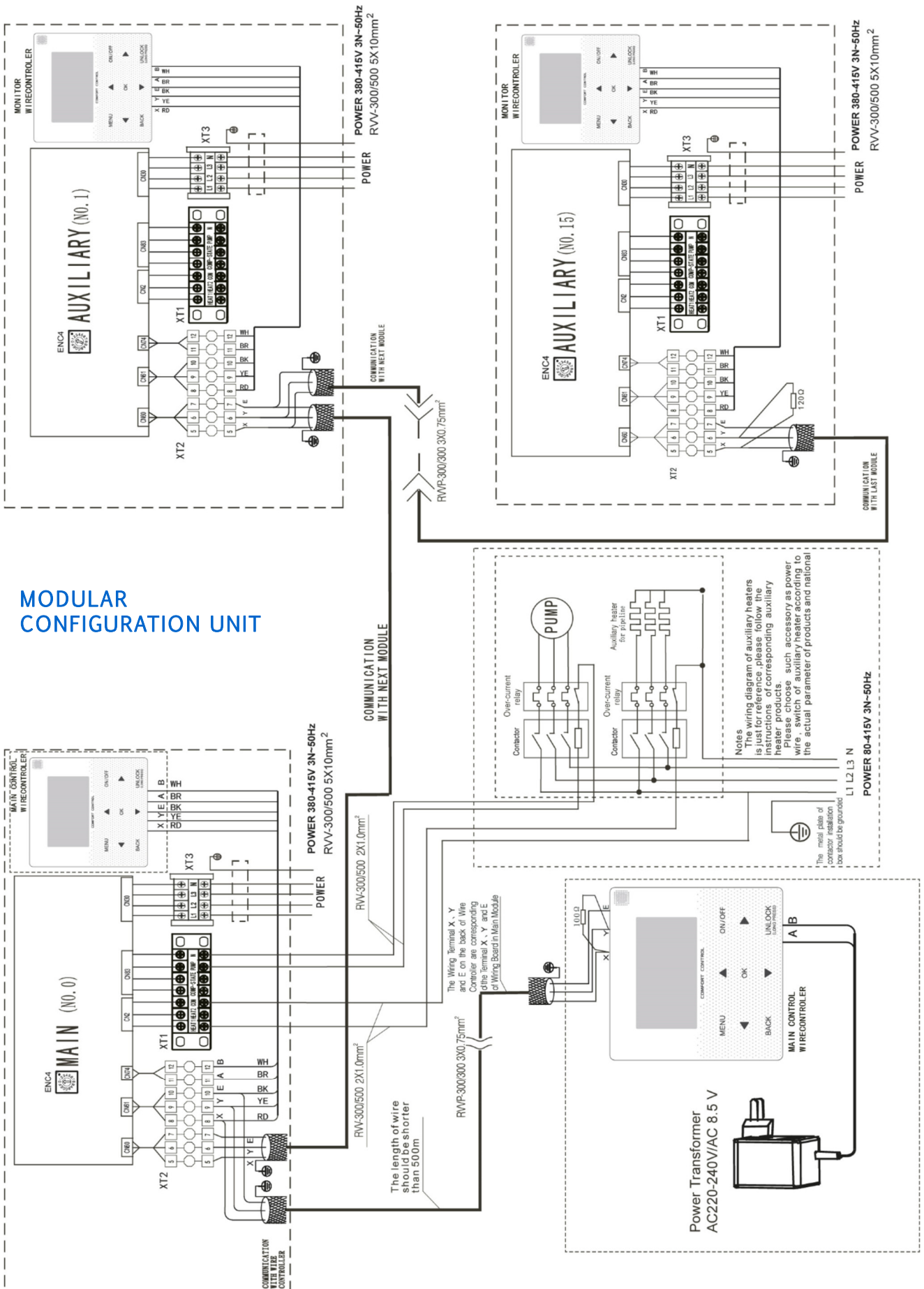

MODBUS

Communication specifications: RS-485

Protocol :ModbusRTU : 9600,8,N,1

Baud rate: 9600bps

Data bits: 8 Data bits

Parity bit : None Parity

Stop bit: 1 stop bit

Connections

Connect on the back of the controller.

Modular unit: connect the modbus to the MASTER unit port.

Enabling

Menu > Project menu> set password > Controller select > MODBUS > ON

Unit address

Modbus address = 2

Function codes

01	query
03	reading
06	single register writing
16	multiple register writing

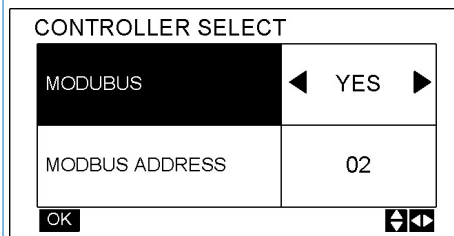
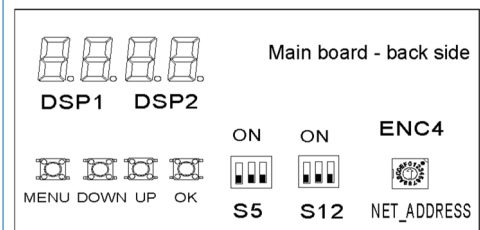
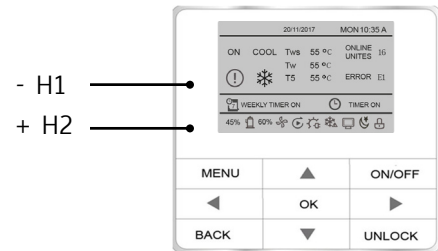

Reading register, writing a single register, multiple register writing

Address	function	notes
0	Mode	(1 Cooling, 2 Heating, 8 Off)
1	Temperature setpoint	COOL (5°C ~ 20°C); HEAT (25°C ~ 54°C)
2	Temperature setpoint B	COOL (5°C ~ 20°C); HEAT (25°C ~ 54°C)
4	water setpoint	30°C~60°C Disponibile per singola unità

Reading and writing register; 100 - 109 read only, 110 reading and writing.

Address	function	notes
101	Double setpoint	Enable/Disable 1/0
102	1st setpoint in cooling	5~20°C
103	2nd setpoint in cooling	5~20°C
104	1st setpoint in heating	25~54°C
105	2nd setpoint in heating	25~54°C
106	temperature compensation in cooling	Enable/Disable
107	point 1 temperature compensation in cooling	25~30°C
108	point 2 temperature compensation in cooling	35~40°C
109	temperature compensation value in cooling	0~15°C
110	temperature compensation in heating	Enable/Disable
111	point1 temperature compensation in heating	0~5°C
112	point2 temperature compensation in heating	15~20°C
113	temperature compensation value in heating	0~15°C

Addresses 0 - 15 are the addresses of the selected units.
 (addresses)*100+240—(addresses)*100+299 , are read only.

Units in modular configuration

Reading logbook

Address	function	notes
240+(Address)*100	Operating mode	1 shutdown 2 cooling 3 heating
241+(Address)*100	SILENT mode	1 Standard 2 Silent 3 Super silent
242+(Address)*100	Setpoint	1°C
243+(Address)*100	Setpoint B	1°C
244+(Address)*100	Two unit inlet water temperature	1°C
245+(Address)*100	Two unit outlet water temperature	1°C
246+(Address)*100	Tw total outlet water temperature	1°C ; only for the master (0)

12 MODBUS

Address	function	notes
247+(Address)*100	Outside temperature	1°C
248+(Address)*100	Compressor speed	1Hz
249+(Address)*100	Compressor input	1A
250+(Address)*100	Fan 1 Speed	Current speed
251+(Address)*100	Fan 2 Speed	Current speed
252+(Address)*100	Fan 3 Speed	Current speed
253+(Address)*100	EXVA	Current position
254+(Address)*100	EXVB	Current position
255+(Address)*100	EXVC	Current position
256+(Address)*100	SV4	0 Off, 1 On
257+(Address)*100	SV5	0 Off, 1 On
258+(Address)*100	SV8A	0 Off, 1 On
259+(Address)*100	SV8B	0 Off, 1 On
260+(Address)*100	4-way valve	0 Off, 1 On
261+(Address)*100	circulation pump	0 Off, 1 On
262+(Address)*100	SV1	0 Off, 1 On
263+(Address)*100	SV2	0 Off, 1 On
264+(Address)*100	HEAT1	0 Off, 1 On
265+(Address)*100	HEAT2	0 Off, 1 On
266+(Address)*100	exhaust air temperature	1°C
267+(Address)*100	return air temperature	1°C
268+(Address)*100	temperature T3A	1°C
269+(Address)*100	temperature Tz	1°C
270+(Address)*100	temperature T5	1°C
271+(Address)*100	P PRESSURE	10 kPa
272+(Address)*100	error / protection	see error codes table
273+(Address)*100	last error / protection	see error codes table
274+(Address)*100	software version	HMI
275+(Address)*100	exhaust air temperature 2	1°C
276+(Address)*100	temperature T3B	1°C
277+(Address)*100	temperature T6A	1°C

Status query register

Register Address	Data	Notes
0	Compressor status	
1	Fan status	
2	Pump status	
3	reserved	
4	reserved	
5	SV1	
6	SV2	
7	reserved	
8	Defrosting	
9	Antifreeze electric heater	
10	Remote control	
11	SILENT mode	Standard, silent, super silent
12	reserved	
13	Alarm signals	
14	Unit group status	1: modular unit 0: single unit

In the BMS reading, register 272, 273 displays one of the follow “error codes” in decimal format, only considering the BYTE LOW. Only consider the last two alphanumeric digits of the code.

Fault Code	E0	E1	E2	E3	E4	E5	E6	E7	E8	E9	EA	Eb	EC	Ed	EE
Fault Number(dec)	1	2	3	4	5	6	7	8	9	10	11	12	13	14	15
Fault Code	EF	EH	EL	EP	EU	P0	P1	P2	P3	P4	P5	P6	P7	P8	P9
Fault Number(dec)	16	17	18	19	20	21	22	23	24	25	26	27	28	29	30
Fault Code	PA	Pb	PC	Pd	PE	PF	PH	PL	PP	PU	H0	H1	H2	H3	H4
Fault Number(dec)	31	32	33	34	35	36	37	38	39	40	41	42	43	44	45
Fault Code	H5	H6	H7	H8	H9	HA	Hb	HC	Hd	HE	HF	HH	HL	HP	HU
Fault Number(dec)	46	47	48	49	50	51	52	53	54	55	56	57	58	59	60
Fault Code	F0	F1	F2	F3	F4	F5	F6	F7	F8	F9	FA	Fb	Fc	Fd	FE
Fault Number(dec)	61	62	63	64	65	66	67	68	69	70	71	72	73	74	75
Fault Code	FF	FH	FL	FP	FU	C0	C1	C2	C3	C4	C5	C6	C7	C8	C9
Fault Number(dec)	75	77	78	79	80	81	82	83	84	85	86	87	88	89	90
Fault Code	CA	Cb	CC	Cd	CE	CF	CH	CL	CP	CU	L0	L1	L2	L3	L4
Fault Number(dec)	91	92	93	94	95	96	97	98	99	100	101	102	103	104	105
Fault Code	L5	L6	L7	L8	L9	LA	Lb	LC	Ld	LE	LF	LH	LL	LP	LU
Fault Number(dec)	106	107	108	109	110	111	112	113	114	115	116	117	118	119	120
Fault Code	d0	d1	d2	d3	d4	d5	d6	d7	d8	d9	dA	db	dC	dd	dE
Fault Number(dec)	131	132	133	134	135	136	137	138	139	140	141	142	143	144	145
Fault Code	dF	dH	dL	dP	dU										
Fault Number(dec)	146	147	148	149	150										

General

The operations indicated should be performed by qualified technicians with specific training on the product.

The electric, hydraulic connections and the other work of the system are the responsibility of the installer.

Upon request, the service centres can perform the start-up; Please agree upon the start-up data with the service centre with sufficient advance.

For details, please refer to the different manual sections.

Before checking, please verify the following :

- the unit should be installed properly and in compliance with this manual.
- the electrical power supply line should be isolated at the beginning
- the line isolator device is open, locked and equipped with the suitable warning sign
- make sure no tension is present

WARNING

⇒ *After switching the power off, wait at least 10 minutes before accessing to the electrical panel or any other electrical component.*

⇒ *Before accessing check with a multimeter that there are no residual stresses.*

Preliminary checks

Unit power supply OFF

		Yes / No
1	safe access	
2	suitable frame to withstand unit weight + people weight	
3	functional clearances	
4	condensation drain	
5	air flow: correct return and supply (no bypass, no stratification)	
6	considered level to be reachable by snow	
7	considered main winds	
8	Lack of chimneys/corrosive atmospheres/pollutants	
9	Structure integrity	
10	Fans run freely	
11	Unit on vibration isolators	
12	Unit input water filter + shut-off valves for cleaning	
13	vibration dampeners on hydraulic connections	
14	expansion tank (recommended volume = 10% system content)	
15	minimum system water content	
16	clean system	
17	loaded system + possible glycol solution + corrosion inhibitor	
18	System under pressure + vented	
19	domestic hot water: valve installed, hydraulically connected, commissioned	
20	Auxiliary heater: installed, hydraulically and electrically connected, commissioned	
21	TW temperature probe: installed, hydraulically connected	
22	refrigerant circuit visual check	
23	earthing connection	
24	power supply features	
25	Remote On-Off / Remote Heat-Cool: electrically connected, commissioned	
26	Modular unit only: bus connection, unit addressing, controller addressing, TW probe on master	

Start-up sequence

Unit power supply ON

		Yes / No
1	Compressor carter resistances operating at least since 8 hours	
2	Off-load voltage measure	
3	Phase sequence check	
4	Pump manual start-up and flow check	
5	refrigeration circuit shut-off valves opening (if applicable)	
6	Unit ON	
7	load voltage measure	
8	If Domestic hot water available: set dip-switch S12-2 on ON	
9	If remote On-Off and remote Heat-Cool are used: set dip-switch S5-3 on ON	
10	If units in modular configuration set dip-switch S12-2 on ON set unit address via ENC4	
11	Verify the lack of bubbles in the liquid light (if applicable)	
12	Check of all fan operating	
13	Measure of return and supply water temperature	
14	Super-heating and sub-cooling measure	
15	Check no anomalous vibrations are present	
16	Set-point personalization	
17	scheduling customisation	
18	Complete and available unit documentation	

Cooling circuit

- 1 Visually inspect the refrigerating circuit: the presence of oil stains can be a symptom of leakage (caused e.g. by transportation, handling or other).
- 2 Verify that the refrigerating circuit is in pressure: Using the unit manometers, if present, or service manometers.
- 3 Make sure that all the service outlets are closed with proper caps; if caps are not present a leak of refrigerant can be possible.
- 4 Open all of the refrigeration circuit shut-off valves (if applicable).

Hydraulic circuit

- 1 Before connecting the unit to the hydraulic system, make sure that the hydraulic system has been washed and that the water has been drained
- 2 Check that the hydraulic circuit has been filled and pressurized-
- 3 Check that the shut-off valves in the circuit are in the "OPEN" position.
- 4 Check that there is no air inside the circuit, and bleed it through the vent valves in the high points of the system if necessary.
- 5 When using antifreeze solutions, make sure the glycol percentage is suitable for the type of use envisaged.

NOTE

⇒ *Neglecting the washing will lead to several filter cleaning interventions and in worst cases can cause damages to the exchangers and the other parts.*

Weight of glycol (%)	10	20	30
Freezing temperature (°C)	-3.9	-8.9	-15.6
Safety temperature	+1	-4	-10

Electric circuit

Check the unit is connected to the earthing system.

Check the conductors are tightened as: the vibrations caused by handling and transport might cause these to come loose.

Power the unit by closing the isolation device but leave in OFF.

Check the network frequency and voltage values, which must be within the limits: 380-415V 3N~ 50Hz +/-6%

Check and adjust the phase balance as necessary: it must be lower than 2%

Example:

$$400 - 6\% = 376$$

$$400 + 6\% = 424$$

NOTE

⇒ *Working outside of these limits can cause irreversible damages and voids the warranty.*

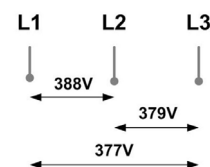

$$1) \frac{388 + 379 + 377}{3} = 381 \text{ (A)}$$

$$2) \text{MAX} - A = 388 - 381 = 7$$

$$3) S = \frac{7}{A} \times 100 = 1,83 \text{ OK}$$

Compressor casing resistances

Connect the compressor oil heating resistances at least 8 hours before the compressor is to be started:

- at the first unit start-up
 - after each prolonged period of inactivity
- 1 Power the heaters: isolator switch on 1 / ON.
 - 2 Check the power consumption of the resistances to make sure that they are functioning.
 - 3 Start-up the compressor only if the crank-case temperature on the lower side is be higher than the outside temperature by at least 10°C .
 - 4 Do not start the compressor with the crankcase oil below operating temperature.

Voltage

Check that the air and water temperatures are within in the operating limits.

Start-up the unit.

While the unit is operative, i.e. in stable conditions nearing operating ones, check:

- Power supply voltage
- Total absorption of the unit
- Absorption of the single electric loads

Remote controls

Check that the remote controls (ON-OFF etc) are connected and, if necessary, enabled with the respective parameters as indicated in the “electrical connections” section.

Check that probes and optional components are connected and enabled with the respective parameters (“electrical connections” section and following pages).

Check the water flow-rate of the evaporator

Check that the difference between the temperature of the exchanger's input and output water corresponds to the potential according to this formula:

$$\text{unit cooling power (kw)} \times 860 = \text{Dt (}^{\circ}\text{C)} \times \text{flow rate (L/h)}$$

The cooling power is shown in the GENERAL TECHNICAL DATA chart included in this manual, referred to specific conditions, or in the

COOLING PERFORMANCE charts in the TECHNICAL BULLETIN referred to various conditions of use.

Check for water side exchanger pressure drops:

Determine the water flow-rate

measure the difference in pressure between the exchanger's input and output water and compare it with the WATER-SIDE EXCHANGER PRESSURE DROPS chart

Measuring the pressure is easier if pressure gauges are installed as indicated in the DIAGRAM OF SUGGESTED WATER CONNECTIONS.

Scroll compressor

Scroll compressors have only one rotation direction.

In the event it is reversed, the compressor is not immediately damaged but it becomes more noisy and pumping is jeopardized.

After a few minutes, the compressor shuts down due to the thermal protection trip.

In this case, disconnect the power supply and invert 2 phases on the machine power supply.

Do not let the compressor work for a long time with opposite rotation: more than 2-3 of these abnormal start-ups can damage it.

To ensure the rotation direction is correct, measure the condensation and suction pressure.

The pressures must differ significantly: upon start-up, the suction pressure decreases while the condensation one increases.

Reduced load operation

The units are equipped with partialisation steps and can therefore operate with reduced loads.

However, a constant and prolonged operation with reduced load with frequent compressor(s) stops and start-ups can cause irreparable damages due to the absence of oil return.

The above-described operating conditions must be considered outside the operating limits.

In the event of a compressor breakdown due to operating in the above-mentioned conditions, the warranty shall not be valid and Clivet spa declines any responsibility.

Periodically check the average operating times and frequency of compressor start-ups: indicatively the minimum thermal load must be such as to require a compressor to operate for at least ten minutes.

If the average times are close to this limit, take the proper corrective actions, for example, increasing the water content of the system is not enough in this application.

Start-up report

To detect the objective operational conditions is useful to control the unit over time.

With unit at steady state, i.e. in stable and close-to-work conditions, identify the following data:

- total voltages and absorptions with unit at full load
- absorptions of the different electric loads (compressors, fans, pumps etc)
- temperatures and flows of the different fluids (water, air) both in input and in output from the unit
- temperatures and pressures in the feature points of the cooling circuit (compressor, liquid, suction drain/unload)

The detections must be kept and made available during maintenance interventions.

Directive 2014/68EU PED

Directive 2014/68EU PED also sets out the regulations for unit installers, users and maintenance operators.

Refer to local regulations; briefly and as an example, see the following:

Compulsory verification of the first installation:

- only for units assembled on the installer's building site (for ex. condensing circuit + direct expansion unit)

Commissioning declaration:

- for all units

Periodical checks:

- to be executed with the frequency indicated by the Manufacturer (see the "maintenance inspections" paragraph)

UNITS IN MULTIPLE CONFIGURATION

Complete system management is carried out by the master unit, identified by address 0.

Thermoregulation takes place on the supply temperature of the entire system (T_w).

At switch-on, when a load is requested, the units are switched on in sequence based on their address, in numerical order.

When the load decreases, the units are switched off following the same sequence.

Example in cooling:

If $T_w \geq \text{set point} + 10^\circ\text{C}$

- the control activates 50% of the resources in sequence based on the set address.
- after a time interval (default: 240 seconds)
- if the load increases, additional resources are activated
- if the load decreases, the units are switched off following the same sequence (first start, first stop).

If $T_w < \text{set point} + 10^\circ\text{C}$ (in cooling)

- the control activates only the master unit.
- after a time interval (default: 240 seconds)
- if the load increases, additional resources are activated based on the set address
- if the load decreases, the master unit switches off.

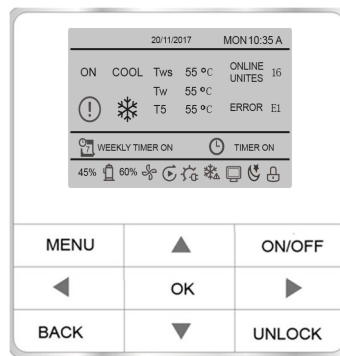

UNLOCK	To lockout / unlock.
▲ ▼	To modify current setpoint
MENU	To open the various menus from the HOME screen.
▲ ▼ ◀ ▶	To move the cursor, change the selection or change the set value. The parameter can be quickly changed with a long press.
OK	To confirm an operation.
ON/OFF	To set the ON / OFF function.
BACK	To return to the previous level. Press to exit the current page and return to the previous page. Long press to return straight to the home screen.

Units in modular configuration

On the slave controllers, only the password-protected SERVICE menu can be opened.

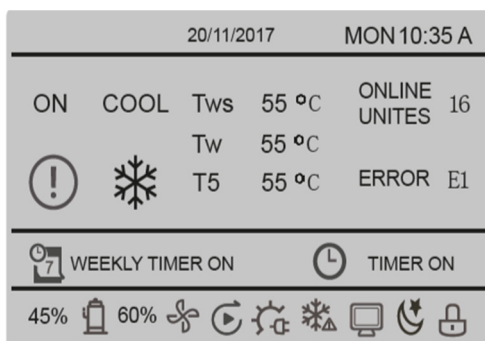

	Mode : indicate respectively heating, cooling, domestic hot water
OFF	Controller off
	Weekly timer active
45%	Compressor use value
	Compressor in operation
60%	Fan use value
	Fan in operation
	Pump in operation
	Auxiliary electric heater in operation.
	Manual antifreeze or defrosting in operation
	Remote control: the unit is set from the keypad to be controlled by a remote terminal or by a remote switch
	SILENT mode.
	Key lock
	Timer on
	Alarm: indicator on when there is a fault or a protection is tripped.

Units in modular configuration

The information displayed on ALL controllers refers to the MASTER unit.

Menu structure

Press “UNLOCK” for 3 seconds to unlock the keypad.

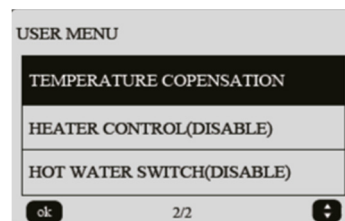
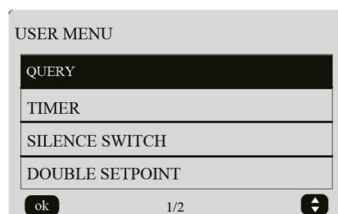
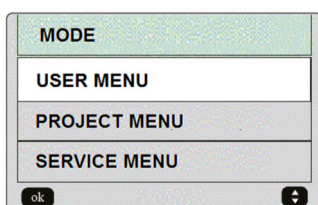

Modo - mode

Riscaldamento / Raffreddamento / ACS - Heat/Cool/Hot water

Menu utente - user mode

Interrogazione - query

Selezionare l'indirizzo da interrogare - Select the query address

Visualizzazione stato - state query

Stato di funzionamento / modalità di funzionamento / modalità silenzio corrente

Operation state / running mode / current silence mode

Visualizzazione temperatura - temp query

Temp. acqua in ingresso / temp. acqua in uscita / temp. totale dell'acqua in uscita / temp. Ambiente -

Inlet-water temp. / outlet water temp. / total out-let water temp. / ambient temp.

Schedulazione - timer

Schedulazione giornaliera - daily timer

Schedulazione settimanale - weekly schedule

Data e ora - date and time

Modalità silenzioso - silence switch

Standard / silenzioso / super silenzioso

standard mode/silent mode/super-silent mode

Doppio set point - double setpoint

Abilitato/disabilitato - enabled/disabled

Compensazione della temperatura - temperature compensation

Modalità riscaldamento / modalità raffreddamento - Cool mode / Heat mode

Controllo resistenza - Heater control

Abilitata/disabilitata - Enable/ disabled

Abilitazione ACS - Hot water switch

Si/no - yes/no

Menu installatore - Project menu *

Menu servizio - Service menu *

Accesso storico allarmi / reset / ecc. - Access alarm log/ reset / etc.

*L'accesso tramite pwd è riservato a personale qualificato modifiche ai parametri possono provocare malfunzionamenti.

Access by pwd is reserved to qualified personnel; Parameter changes may cause malfunctions

Menu installatore - project menu*

Impostare l'unità - Set unit air-conditioning

Impostare unità parallele - Set parallel unit

Impostare protezione dell'unità - Set unit protection

Impostare lo sbrinamento - Set defrosting

Impostare la resistenza - Set heater

Verifica componenti - Check parts

Selezionare controllo - Controller select

Controllo del convertitore della pompa - Pump converter control

<p>Namely: Press ▲ or ▼ to adjust the values, scroll through the lists Press ◀ or ▶ to select Press OK to go to the next menu Press BACK to go to the previous menu</p>	
<p>Unlock/lock To lockout the screen, press UNLOCK for 3 sec.</p> <p>Switch-on/off Press ON/OFF to switch-on/off</p>	
<p>Units in modular configuration On the slave controllers, only the password-protected SERVICE menu can be opened.</p>	

Set MODE and TEMPERATURE

Press MENU
 Press ▲ or ▼ to select MODE
 Press OK
 Press ◀ or ▶ to select the mode or the temperature
 Press ▲ or ▼ to adjust the mode and temperature.
 Press OK to confirm.

If no operations are performed for more than 60 seconds, the system automatically saves the settings and returns to the home page.

Note

During cooling with T ext < 15°C, the setpoint is forced to 10 °C (ref. Functioning limits)

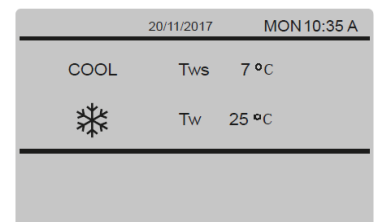
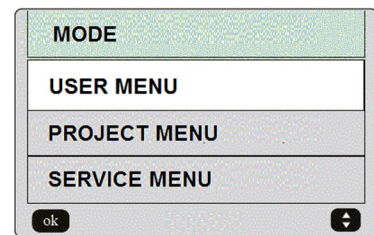

DOMESTIC HOT WATER

The ACS, if present and enabled, must be activated.

Press MENU
 Press ▲ or ▼ to select MODE
 Press OK
 Press t or u to select the DHW mode
 Press On-Off
 Press OK to confirm.

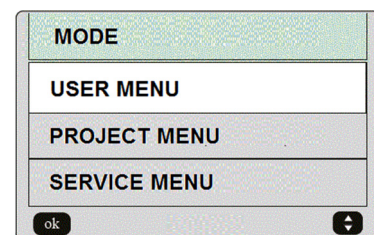

USER MENU

Press MENU

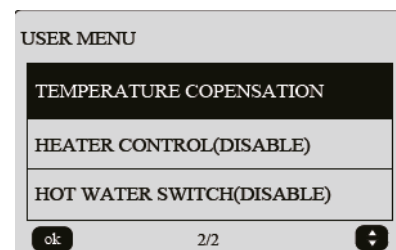
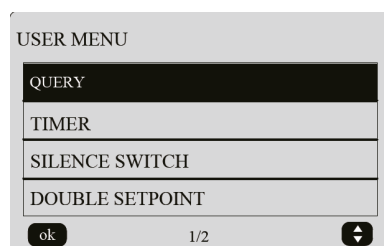

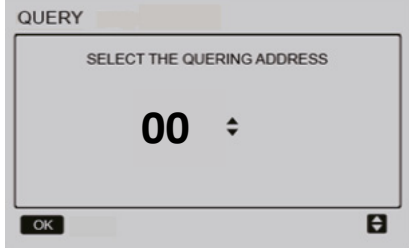
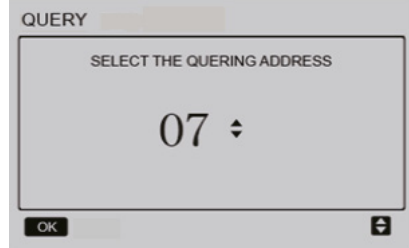
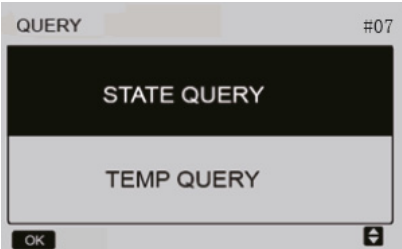
<h2 style="margin: 0;">USER MENU - QUERY</h2>																	
<p style="color: blue; margin: 0;">Only if multiple units are connected to the network</p> <p>To display data for the units in the network: Press MENU Press ▲ or ▼ to select QUERY Press ▲ or ▼ to select the unit's address Press OK</p>																	
<p>If STATE QUERY is selected:the unit's address is shown at top right (only for units in modular configuration)</p>																	
	<table border="1" style="width: 100%; border-collapse: collapse; text-align: center;"> <tr> <td colspan="4" style="padding: 5px;">STATE QUERY #07</td> </tr> <tr> <td style="padding: 5px;">OPERATION STATE</td> <td style="padding: 5px;">RUNNING MODE</td> <td colspan="2" style="padding: 5px;">CURRENT SILENT MODE</td> </tr> <tr> <td style="padding: 5px;">ON</td> <td style="padding: 5px;">COOL</td> <td colspan="2" style="padding: 5px;">NIGHT SILENT MODE</td> </tr> <tr> <td colspan="4" style="padding: 5px;">BACK</td> </tr> </table>	STATE QUERY #07				OPERATION STATE	RUNNING MODE	CURRENT SILENT MODE		ON	COOL	NIGHT SILENT MODE		BACK			
STATE QUERY #07																	
OPERATION STATE	RUNNING MODE	CURRENT SILENT MODE															
ON	COOL	NIGHT SILENT MODE															
BACK																	
<p>If TEMP QUERY is selected:</p>	<table border="1" style="width: 100%; border-collapse: collapse; text-align: center;"> <tr> <td colspan="4" style="padding: 5px;">TEMP QUERY #07</td> </tr> <tr> <td style="padding: 5px;">IN-LET WATER TEMP.</td> <td style="padding: 5px;">OUT-LET WATER TEMP.</td> <td style="padding: 5px;">TOTAL OUT-LET WATER TEMP.</td> <td style="padding: 5px;">AMBLENT TEMP.</td> </tr> <tr> <td style="padding: 5px;">25°C</td> <td style="padding: 5px;">25°C</td> <td style="padding: 5px;">25°C</td> <td style="padding: 5px;">25°C</td> </tr> <tr> <td colspan="4" style="padding: 5px;">BACK</td> </tr> </table>	TEMP QUERY #07				IN-LET WATER TEMP.	OUT-LET WATER TEMP.	TOTAL OUT-LET WATER TEMP.	AMBLENT TEMP.	25°C	25°C	25°C	25°C	BACK			
TEMP QUERY #07																	
IN-LET WATER TEMP.	OUT-LET WATER TEMP.	TOTAL OUT-LET WATER TEMP.	AMBLENT TEMP.														
25°C	25°C	25°C	25°C														
BACK																	

USER MENU - TIMER

Press MENU

Press TIMER

Select one of the 3 categories proposed

If “DAILY TIMER” is selected, the “WEEKLY SCHEDULE” cannot be activated and vice versa.

If the unit is controlled via a remote On-Off or Modbus, DAILY and WEEKLY timers are disabled.

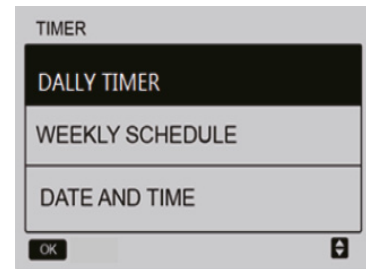

TIMER menu - DAILY TIMER

Press ▲ or ▼ to select timer 1 or timer 2

Press ON/OFF when the cursor is over the word ACT

Press ◀ or ▶ to select the starting time, the end time and the mode

Press ▲ or ▼ to select the time, mode, temperature, silent mode

Press ◀ or ▶ to set the silent, standard, night silent or super silent modes

Press to confirm

The “ Timer on” symbol appears on the main screen

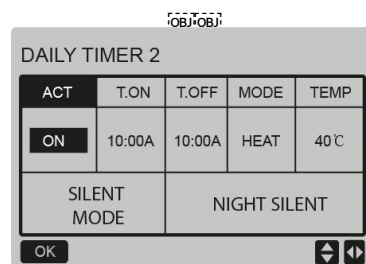
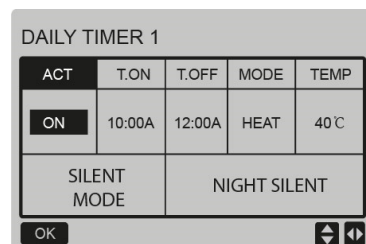

If two time slots overlap, the last one on the lists is activated (in figure OFF)

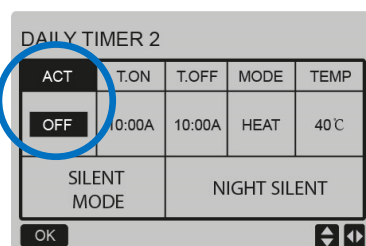

TIMER menu - WEEKLY TIMER

Select WEEKLY SCHEDULE
 Press ▲ or ▼ to select the day
 Set ON or OFF
 Press OK to confirm

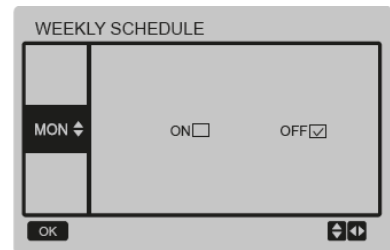

Press ▲ or ▼ to select timer 1 or timer 2
 Press ON/OFF when the cursor is over the word ACT
 Press ◀ or ▶ to select the starting time, the end time and the mode
 Press ▲ or ▼ to select the time, mode, temperature, silent mode
 Press ◀ or ▶ to set the silent, standard, night silent or super silent modes
 Press OK to confirm
 The “🕒 7 Weekly timer on” symbol appears on the main screen

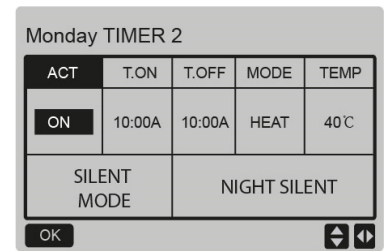
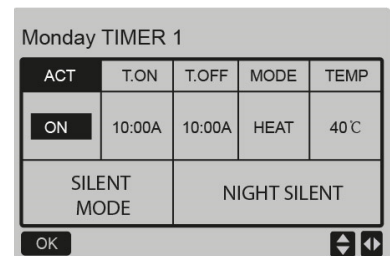

TIMER menu - DATE and TIME

Select DATE AND TIME
 Select DATE to change the date
 Select TIME to change the time

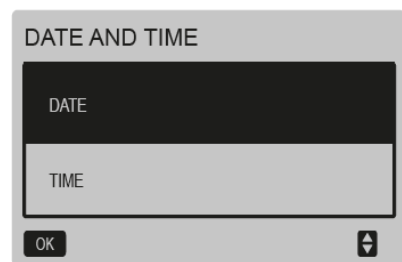

USER menu - SILENT MODE SWITCH

Press ◀ or ▶ to select the mode:
Standard, Silent, Supersilent
Press OK to save the settings

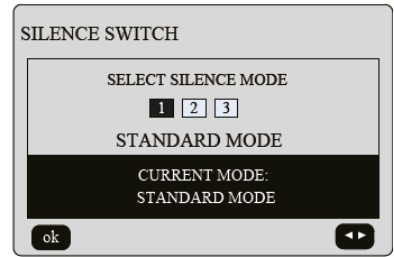

USER menu - DOUBLE SETPOINT

Press ▲ or ▼ to ENABLE or DISABLE.

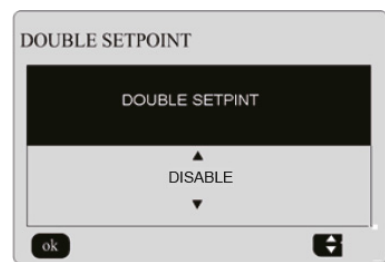

Enable the double setpoint

Press ◀ or ▶ to select the setpoint mode
Press ▲ or ▼ to adjust the parameters

The 2nd setpoint is activated only if the “temp-switch” input on the terminal block XT2 is closed

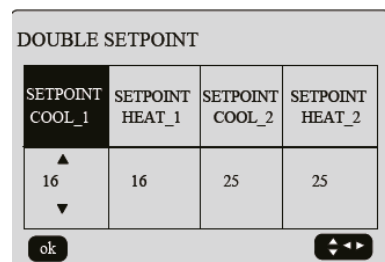

USER menu - TEMPERATURE COMPENSATION

Press ▲ or ▼ to select:

COOL MODE

HEAT MODE

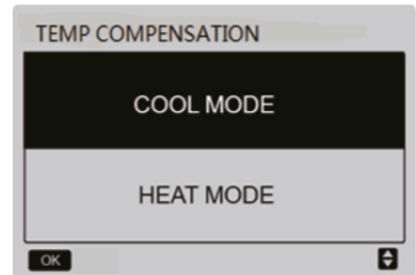

The water temperature is adjusted based on the outdoor temperature T_4 .

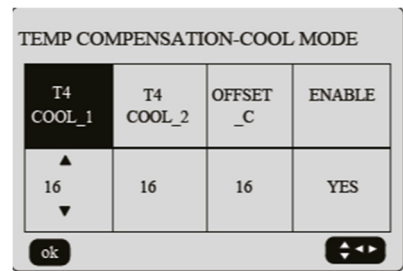

COOLING

The following parameters can be adjusted:

- $T4_{cool_1}$ (25~30°C)
- $T4_{cool_2}$ (30~40°C)
- $offset_c$ (0~15°C)

HEATING

The following parameters can be adjusted:

- $T4_{heat_1}$ (0~5°C)
- $T4_{heat_2}$ (15~20°C)
- $offset_h$ (0~15°C)

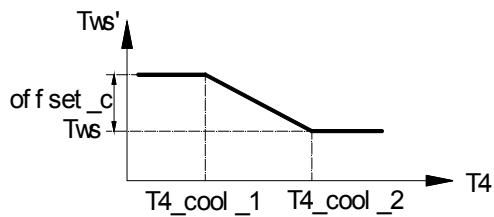

<p>USER MENU - DOMESTIC HOT WATER Select HOT WATER</p>	
<p>single unit</p>	
<p>units in modular configuration select address</p>	
<p>enable domestic hot water, if applicable activate priority of domestic hot water, if applicable</p>	
<p>minimum and maximum operating times of the unit once it has entered the corresponding mode</p>	

<p>USER MENU - AUXILIARY HEATER domestic hot water storage (wiring diagram: KA-H2) select heater control</p>	<p>USER MENU</p> <p>TEMPERATURE COPENSATION</p> <p>HEATER CONTROL(DISABLE)</p> <p>HOT WATER SWITCH(DISABLE)</p> <p>ok 2/2</p>
	<p>HEATER CONTROL</p> <p>FORCED HEAT 2 OPEN</p> <p>OK</p>
<p>single unit</p>	<p>FORCED HEAT2 OPEN</p> <p>FORCED HEAT2 OPEN:</p> <p>◀ YES ▶</p> <p>ok</p>
<p>units in modular configuration select address</p>	<p>FORCED HEAT2 OPEN</p> <p>00 01 02 03 04 05 06 07</p> <p>08 09 10 11 12 13 14 15</p> <p>ok</p>

<p>PROJECT MENU Inverter pump Select Pump Converter Control</p>	<p>PROJECT MENU CONTROLLER SELECT PUMP CONVERTER CONTROL OK 2/2</p>
<p>Unità in configurazione modulare Select address</p>	<p>SELECT THE PUMP ADDRESS 00 01 02 03 04 05 06 07 08 09 10 11 12 13 14 15 ok</p>
<p>Single unit</p>	<p>PUMP CONVERTER CONTROL ENABLE/DISABLE RATIO_PUMP DISABLE 100% OK</p>

Alarm reset: turn the unit off and on again.

NOTE

⇒ *Before resetting an alarm, identify and remove the cause generating that.*

⇒ *Repeated resets can cause irreversible damage.*

Master unit

If the Master unit's power supply is disconnected, all of the group's units stop.

- The unit is in protection in the following conditions:
- High pressure or protection due to drain temperature
- low voltage
- compressor current protection
- frequency protection of the inverter compressor
- condenser high temperature
- high temperature difference between the input and output water
- antifreeze protection
- drain temperature sensor malfunction
- low evaporator temperature
- frequency protection by voltage
- compressor inverter malfunction
- fan motor protection
- water return high temperature, in cooling
- low pressure antifreeze protection
- high temperature of inverter compressor module

When the unit fails or is in protection, the water pump continues working (except for water flow alarm, voltage protection, phase sequence protection).

When the master unit is in protection, only the master unit stops and the other units carry on working.

When a slave unit is in protection, this unit stops and the other units are not involved.

If the master unit fails, the slave units also stop working.

Temperature sensors

All temperature sensors are classed as faulty when the voltage on the corresponding input is lower than 0.05 V or higher than 4.95 V.

After an error has been signalled, all units stop. The error is eliminated after the sensor has been restored.

Error code	Description	troubleshooting
1E0	EEPROM error - main board	
2E0	EEPROM error - inverter A module	
3E0	EEPROM error - inverter B module	
E1	phases sequence - control from main board	The three phases must be present at the same time and offset by 120°. Restoring the power supply clears the error. Note: the power supply is checked only in the initial switch-on phase. It is not controlled when the unit is in operation.
E2	communication error between main board and keypad	If an error occurs between the wired controller and the master unit module, all of the slave units stop. If an error occurs in a slave unit (between the master unit and a slave unit), the slave module with the transmission error stops. The number of controlled units on the wired controller is reduced, the wired controller displays EC and the wired controller indicator flashes. The error is eliminated after the transmission has been restored. If an error occurs between slave units, both units stop. The master unit and the previous slave units are not involved.
E3	“Total” outlet water temperature probe Tw fault (only for master unit)	Only the master unit controls the sensor fault, the slave unit does not control it. When the number of units in line is 2 or more, check if the Tw sensor is faulty or is not required. When the number of units in line is 1, Tw = Two by default; check if the Tw sensor is faulty or is not required.
E4	outlet water temperature probe Two fault	
1E5	condenser temperature probe T3A fault	
2E5	condenser temperature probe T3B fault	
E6	storage temperature probe T5 fault	
E7	room temperature probe T4 fault	
E8	phases sequence	It is controlled continuously. If the protection occurs on the master unit, all of the units stop and reset automatically. If the protection occurs on a slave unit, it stops and resets automatically, the master unit and the other slave units are not involved.

E9	no flow (manual reset) Ddained system	Turn the power off to reset it.Active 120 seconds from the start-up
1Eb	antifreeze probe Taf1 fault	
2Eb	antifreeze probe Taf2 fault	
EC	Slave unit module reduction	
1Ed	compressor drain temperature probe A	
2Ed	compressor drain temperature probe B	
1EE	refrigerant temperature probe T6A	
2EE	refrigerant temperature probe T6B	
EF	return water temperature probe	
EH	autotest error	
EP	drain temperature probe	Detection begins 10 minutes after start-up. The protection intervenes if the heating P_c is ≥ 3.5 MPa for 2 minutes or cooling $T_z \geq 56^\circ\text{C}$ and the drain temperature $T_{pmax} < 15^\circ\text{C}$. The entire unit stops. Turn the power off to reset it.
EU	condenser total temperature probe T_z	
P0	high pressure / drain temperature	If the protection intervenes 10 times in 150 minutes, turn the power off to reset it
P1	low pressure	At start-up the low pressure switch is bypassed for 3 minutes.If the protection intervenes 10 times in 150 minutes, turn the power off to reset it. If there is a remote control, turn the power off to reset it.
P2	total condenser output high temperature T_z	
P4	compressor A in protection	Absorption is not controlled during the first 10 seconds after the compressor has started. If the protection intervenes 10 times in 150 minutes, turn the power off to reset it. If there is a remote control, turn the power off to reset it.
P6	module error	
P7	condenser high temperature	
P8	Reserved	

P9	Inlet / outlet water temperature difference	If the protection intervenes 3 times in 60 minutes, turn the power off to reset it. Verify: That Two probes are positioned correctly in the well. The functioning of the circulation pump Flow within the allowed range
PA	Reserved	
Pb	winter antifreeze	
PC	evaporator low pressure in cooling	
PE	antifreeze protection evaporator low temperature in cooling	If the protection intervenes 3 times in 60 minutes, turn the power off to reset it. Check that probe Two is positioned correctly in the well.
PF	circuit board lock - controller lock/unlock error	
PH	high room temperature probe T4	
PL	Tfin module, high temperature	If the protection intervenes 3 times in 100 minutes, turn the power off to reset it.
1PP	IPM module error, circuit A	
2PP	IPM module error, circuit B	
1PU	fan A module	
2PU	fan B module	
3PU	fan C module	
1H9	compressor driver A - configuration error	
2H9	compressor driver B - configuration error	
H5	High / low voltage	
1HE	valve A error	
2HE	valve B error	
3HE	valve C error	
1F0	IPM module transmission error	
2F0	IPM module transmission error	
F2	insufficient overheating	If the protection intervenes 3 times in 240 minutes, turn the power off to reset it.
1F3	Fan A transmission error	
2F3	Fan B transmission error	
3F3	Fan C transmission error	
1F4	protection L0 or L1 intervention 3 times in 60 minutes	

2F4	protection L0 or L1 intervention 3 times in 60 minutes	
1F6	circuit A bus voltage (PTC)	
2F6	circuit B bus voltage (PTC)	
F7	Reserved	
1F9	radiator temperature sensor Tfin1	
2F9	radiator temperature sensor Tfin2	
1FA	Reserved	
2FA	Reserved	
Fb	pressure sensor	Detection begins 15 minutes after start-up, if a pressure lower than 0.3 MPa is detected. Not detected during defrosting.
Fd	return air temperature sensor	
FE	recovery temperature sensor	
1FF	fan A	
2FF	fan B	
3FF	fan C	
FP	DIP switch for modular unit configuration error	
C7	3 times PL	
L0	module protection	
L1	low voltage	
L2	high voltage	
L4	MCE error	
L5	speed 0	
L7	no phase	
L8	variation of frequency higher than 15Hz	
L9	difference of phase frequency higher than 15Hz	
d0	Gate error (d0 and address alternatively displayed every 10 sec)	
dF	defrosting	

STATUSES DISPLAY

Press UP on the main sheet

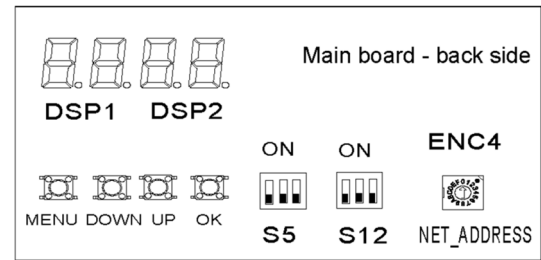

	Standby: unit address (88 to the left) + online number (88 to the right) On: frequency defrosting: dFdF
0.xx	unit address
1.xx	high pressure
2.xx	number of units
3.xx	T4 correction
4.xx	Mode (8: Off; 0: Standby; 1: Cooling; 2: Heating)
5.xx	fan speed 1
6.xx	fan speed 2
7.xx	T3: coil temperature
8.xx	T4: outside temperature
9.xx	T5: DHW temperature:
10.xx	Taf1: exchanger outlet temperature, antifreeze protection
11.xx	Taf2: exchanger outlet temperature, antifreeze protection
12.xx	Tw: common outlet water temperature, after the last unit
t.xx	Two inlet water
14.xx	Two outlet water
15.xx	Tz total outlet water
16.xx	THeatR recovery
17.xx	supply 1
18.xx	supply 2
19.xx	Radiation fin temperature 1
20.xx	Radiation fin temperature 2
21.xx	saturated drain temperature (+25)
22.xx	Compressor current A
23.xx	Compressor current B
24.xx	Pump current
25.xx	electronic expansion valve opening A (/20)

26.xx	electronic expansion valve opening B (/20)
27.xx	electronic expansion valve opening C (/4)
28.xx	high pressure
L.xx	low pressure
30.xx	overheating
31.xx	intake temperature
32.xx	silent
33.xx	static pressure
34.xx	DC voltage A (reserved)
35.xx	DC voltage B (reserved)
36.xx	frequency limit (0 = None; 1 = T4 ; 2 = pressure; 3 = drain; 4 = low pressure ratio; 5 = Real-time ; 6 = Current frequency ; 7: = voltage; 8: Adjustment of energy requirement of pressure ratio ; 9 = low pressure in cooling)
37.xx	defrosting status (1st digit: T4 selection solution; 2nd digit: at intervals ; 3rd and 4th digit defrosting on timer)
38.xx	EPROM error: 1: Error; 0: No error
39.xx	defrosting
40.xx	initial frequency
41.xx	Tc: Saturation temperature corresponding to high pressure in heating mode
42.xx	Te: Saturation temperature corresponding to low pressure in cooling mode
43.xx	T6a: exchanger inlet temperature
44.xx	T6b: exchanger outlet temperature
45.xx	software version
46.xx	last error
47.xx	----

SAFETY WARNINGS FOR OPERATIONS ON UNITS CONTAINING R32

Area checks

Before working on systems containing flammable refrigerants, perform safety checks to reduce the risk of combustion to the minimum. Before performing any repair operations on the cooling system, comply with the following warnings.

Work procedures

Operations must be performed following a controlled procedure so as to reduce the risk of flammable gases or vapours developing.

General work area

All the personnel in charge with maintenance operations and other operators working in the local area must be instructed and monitored as regards the nature of the intervention.

Avoid working in tight spaces. The area surrounding the working space must be cordoned off. Make sure the area is secured by monitoring the flammable material.

Check the presence of refrigerant

Both before and during operations, the area must be monitored with a dedicated refrigerant detector to make sure the technician is aware of the presence of potentially-flammable environments.

Make sure the leak detection equipment is suitable for use with flammable refrigerants and therefore without sparks, suitably sealed or intrinsically safe.

Presence of the fire extinguisher

If hot interventions are not performed on cooling equipment or connected components, suitable fire fighting equipment must be kept at hand.

Keep a dry-powder or CO2 extinguisher near the loading area.

No ignition source

It is absolutely forbidden to use ignition sources that may lead to fire or explosion during operations on the cooling system or on pipes that contain or have contained flammable refrigerant.

All possible ignition sources, including cigarettes, must be kept sufficiently away from the installation, repair, removal and disposal site as flammable refrigerant may be released in the surrounding area.

Before starting operations, the area surrounding the equipment must be inspected to guarantee the absence of flammables or combustion risks. "SMOKING IS FORBIDDEN" signs must be affixed.

Ventilated area

Before intervening on the system or performing any hot intervention, make sure to be in an outdoor or suitably ventilated area.

Ventilation must be maintained during operations. Ventilation must disperse the released refrigerant safely, preferably outdoors in the atmosphere.

Cooling equipment checks

Should a replacement be necessary, the new components installed must be suitable for the purpose envisaged and compliant with specifications.

Always follow the manufacturer guidelines on maintenance and assistance. In case of doubt, contact the manufacturer technical office for assistance.

The following checks must be performed on systems containing flammable refrigerants:

- the quantity of the charge must comply with the size of the room where the parts containing refrigerant are installed;
- the machine and ventilation intake function correctly and are not obstructed;
- If an indirect cooling circuit is used, the secondary circuits must be checked to verify the presence of refrigerants; the marking on the equipment remains visible and readable;
- Make sure markings and symbols are always readable; cooling pipes or components must be installed in a position that makes improbable their exposure to substances that may corrode the components

containing refrigerant, unless they are manufactured with material intrinsically resistant to corrosion or suitably protected against corrosion.

Electrical device checks

The reparation and maintenance of electric components must include initial safety checks and component inspection procedures.

In case of a fault that compromises safety, do not perform any electrical connection to the circuit until said fault is suitably resolved.

If it is not possible to repair the fault immediately and electrical components need to remain functioning, a temporary solution must be adopted. This must be reported to the owner of the equipment so as to keep all parties informed.

Initial safety checks must include:

- that condensers are emptied. This operation must be performed safely to avoid any sparks;
- that electrical components and wiring are not exposed during the charging, recovering or venting phases;
- That the earth conductor is continuous.

Repairing sealed components

- During the reparation operations of sealed components, disconnect all the equipment before removing sealed casings etc. If, during operations, it is absolutely necessary for the equipment to remain connected, a leak detection device must be placed in the most critical point so as to report any potentially-dangerous situation.
- Pay particular attention to what follows to guarantee that, while intervening on electrical components, the housing is not altered in a way so as to affect the level of protection. This includes damage to cables, an excessive number of connections, terminals not compliance with the original specifications, damage to gaskets, an unsuitable installation of gaskets, etc.
- Make sure the device is installed safely.
- Check that the seals or sealing materials are not altered in such a way that they no longer the impede the entry of flammable environments. Spare parts must comply with manufacturer specifications.

NOTE:

⇒ *Using silicone sealants may inhibit the effectiveness of a few types of leak detection equipment. It is not necessary to isolate intrinsically safe components before performing operations on them.*

Reparation of intrinsically safe components

Do not apply permanent inductive or capacitive loads to the circuit without making sure that they do not exceed the admissible voltage and current allowed for equipment in use.

Intrinsically safe components are the only component type on which operations can be performed in a flammable atmosphere. The testing device must show a correct value. Replace components only with the parts specified by the manufacturer.

Following a leak, other parts could lead to the combustion of the refrigerant in the atmosphere.

Wires

Make sure wires are not subjected to wear, corrosion, excessive pressure or vibration, that there are no sharp edges and that they do not produce other negative effects on the environment. The inspection must also keep into consideration the effects of time or the continuous vibration caused e.g. by compressors or fans.

Detection of flammable refrigerants

Under no circumstance is it possible to use potential ignition sources to search or detect refrigerant leaks.

Do not use halide lights (or any other open flame detectors).

Leak detection methods

The following leak detection methods are considered acceptable for systems containing flammable refrigerants. Electric leak detectors must always be used to identify flammable refrigerants, although they do not present a suitable sensitivity level or require recalibration (detection equipment must be calibrated in an area free from refrigerants).

Check that the detector is not a possible source of ignition and that it is suitable for the refrigerant. Leak detection equipment must always be set to an LFL percentage and calibrated depending on the refrigerant used, so the correct gas percentage (25% max) must be verified.

Leak detection fluids are suitable for most refrigerants, although using detergents containing chlorine should be avoided as this substance may react with the refrigerant and corrode copper pipes.

If a leak is suspected, all open flames must be removed or switched off.

If a leak is identified that requires brazing, all the refrigerant must be recovered from the system or isolated (using interception valves) in a section of the system far away from the leak. Oxygen-Free-Nitrogen (OFN) is then purged through the system both before and during the brazing procedure.

Removal and evacuation

When intervening on the cooling circuit to perform repair work or any other type of work, always follow the normal procedure. However, considering the risk of flammability, we recommend following the best practices. Comply with the following procedure:

- remove the refrigerant;
- purge the circuit with inert gas;
- evacuate;
- Purge again with inert gas;
- Interrupt the circuit with interruption or brazing.

The refrigerant charge must be collected in suitable recovery tanks. To make the unit safe, flushing with Oxygen-free-Nitrogen must be performed. This procedure may have to be repeated multiple times. Do not use compressed air or oxygen for this operation.

Flushing is obtained interrupting the system vacuum with OFN and filling until the operating pressure is obtained, then releasing into the atmosphere and restoring the vacuum. This process must be repeated until there is no trace of refrigerant in the system.

When using the final OFN charge, the system must be vented to the atmospheric pressure to allow the intervention. This step is essential to perform brazing operations on the pipes.

Make sure that the vacuum pump intake is not near ignition sources and that there is suitable ventilation.

Charging operations

In addition to conventional charging operations, the following requirements must be complied with:

- When using charging equipment, make sure that the various refrigerants are not contaminated. Flexible tubes or conduits must be as short as possible to reduce to the minimum the quantity of refrigerant contained.
- Tanks must be kept in a vertical position.
- Before loading the system with refrigerant, check that the cooling system is earthed.
- Label the system when fully charged (unless already labelled).
- Make sure not to fill the cooling system excessively.
- Before recharging the system, the pressure must be tested with OFN. A leak test must be performed after the charging operations but before commissioning. Before leaving the site, perform an additional leak test.

Dismantling

Before performing this procedure, it is essential that the technician has become familiar with the equipment and the relative details.

We recommend employing good practices for a safe recovery of the refrigerants.

Before performing the operation, take a sample of oil and refrigerant should an analysis be necessary before reusing the regenerated refrigerant. Before performing the operation, check the availability of electricity.

- Become familiar with the equipment and how it functions.

- Electrically isolate the system.

Before attempting the procedure, check that:

- The mechanical manipulation equipment is available, if necessary, to handle refrigerant tanks;
- All the personal protection equipment is available and employed correctly;
- The recovery procedure is monitored at all times by skilled personnel;
- The recovery equipment and tanks comply with suitable standards.
- If possible, pump the cooling system.
- If it is not possible to obtain a vacuum, make sure that a collector removes the refrigerant from various parts of the system.
- Before proceeding with the recovery, check that the tank is located on the scales.
- Start up the recovery machine and use it following the instructions by the manufacturer.
- Do not fill the tanks excessively. (Do not exceed 80% of the liquid volume).
- Do not exceed the tank's maximum operating pressure, not even momentarily.
- Once the tanks are filled correctly and the process is over, make sure that the tanks and equipment are immediately removed from the site and that all insulation valves on the equipment are closed.
- The refrigerant recovered must not be loaded into another cooling system unless it has been cleaned and checked.

Labelling

Equipment must be labelled reporting the dismantling and emptying of the refrigerant.

Labels must be dated and signed.

Make sure all the equipment is labelled and reporting the presence of flammable refrigerant.

Recovery

When removing the refrigerant from the system, please adopt good practices to remove all refrigerants safely in case of both assistance or decommissioning operations.

When transferring the refrigerant into the tanks, make sure only suitable tanks are used to recover the refrigerant.

Make sure enough tanks are used.

All the tanks to be used are designated for the recovered refrigerant and are labelled for that specific refrigerant (e.g. special tanks for refrigerant collection).

Tanks must be equipped with a perfectly-functioning safety valve and relative interception valves.

Empty recovery tanks are evacuated and, if possible, cooled before recovery.

Recovery equipment must be perfectly functioning with the respective instruction booklets at hand and they must be suitable to recover flammable refrigerants. A series of perfectly-functioning calibrated scales must also be available.

Flexible tubes must be equipped with leak-proof disconnection fittings in good condition. Before using the recovery machine, make sure it is in good condition, maintained and that all associated electrical components are sealed to avoid combustion in case of a refrigerant leak. Please contact the manufacturer in case of doubt.

The refrigerant recovered must be taken to the supplier in suitable recovery tanks and with the relative waste transfer note suitably filled in.

Do not mix the refrigerants in the recovery units nor in the tanks.

If it is necessary to remove compressors or compressor oils, make sure they are evacuated to an acceptable level to make sure no trace is left of the flammable refrigerant inside the lubricant. The evacuation process must be performed before taking the compressors back to the suppliers.

The electric resistance must be used with the compressor body only to accelerate this process.

Operations to discharge the oil from the system must be performed in full safety.

20. Transport, mark and storage

- 1 Transport of equipment containing flammable refrigerants
Compliance with transport regulations

- 2 Marking of equipment with symbols
Compliance with local regulations
- 3 Disposal of equipment employing flammable refrigerants
Compliance with national regulations
- 4 Storage of equipment/devices
The equipment must be stored in compliance with the instructions provided by the manufacturer.
- 5 Storing packed (unsold) equipment
Packing must be performed in such a way that mechanical damage to the equipment inside it does not cause refrigerant leaks.
The maximum number of elements that can be stored together is determined by local regulations.

General

Maintenance must be performed by authorized centres or by qualified personnel

The maintenance allows to:

- maintaining the unit efficient
- reduce the deterioration speed all the equipment is subject to over time
- collect information and data to understand the efficiency state of the unit and prevent possible faults

WARNING

- ⇒ *Before checking, please verify the following:*
- ⇒ *the electrical power supply line should be isolated at the beginning*
- ⇒ *the line isolator device is open, locked and equipped with the suitable warning sign*
- ⇒ *make sure no tension is present*
- ⇒ *After switching the power off, wait at least 5 minutes before accessing to the electrical panel or any other electrical component.*
- ⇒ *Before accessing check with a multimeter that there are no residual stresses.*

Frequency of interventions

Perform an inspection every 6 months.

However, frequency depends on the type of use.

Plan inspections at close intervals in the event of:

- frequent use (continuous or very intermittent use, near the operating limits, etc)
- critical use (service necessary)

WARNING

- ⇒ *Before performing any work, please read carefully: SAFETY WARNINGS FOR OPERATIONS ON UNITS CONTAINING R32*



	intervention frequency (months)	1	6	12
1	Presence of corrosions			X
2	Panel fixing			X
3	Fan fixing		X	
4	coil cleaning		X	
5	Water filter cleaning		X	
6	water: quality, pH, glycol concentration		X	
7	check exchanger efficiency			X
8	circulation pump		X	
9	Check of the fixing and the insulation of the power lead			X
10	earth cable check			X
11	Electric panel cleaning			X
12	power remote controls status			X
13	clamp closure, cable isolation integrity			X
14	Voltage and phase unbalancing (no load and on-load)		X	
15	Absorptions of the single electrical loads		X	
16	compressor casing heaters test		X	
17	Checking for leaks *			*
18	cooling circuit work parameter detection		X	
19	safety valve *			*
20	protective device test: pressure switches, thermostats, flow switches etc..			X
21	control system test: setpoint, climatic compensations, capacity stepping, air flow-rate variations			X
22	Control device test: alarm signalling, thermometers, probes, pressure gauges etc			X

NOTE

⇒ Refer to the local regulations. Companies and technicians performing installation, maintenance/repair, leak control and recovery operations must be CERTIFIED as set out by the local regulations.

Unit booklet

Foresee a unit schedule to keep trace of the interventions made on the unit.

In this way, it will be easier to adequately schedule the various interventions and facilitate any troubleshooting.

On the schedule note:

- date
- intervention description
- carried out measures etc.

Standby mode

If foreseen a long period of inactivity:

- turn off the power
- Prevent the risk of freezing (use glycol or empty the system) disconnect voltage to avoid electric risks or damages following lightning

With lower temperatures keep heaters turned on in of the electrical panel (option).

It is recommended to have a qualified technician start the system after a period of inactivity, especially after seasonal stops

or for seasonal switch-overs.

When starting, follow the instructions in the “start-up” section.

Schedule technical assistance in advance to avoid hitches and to guarantee that the system can be used when required.

System drain

- 1 empty the system
- 2 empty the exchanger, use all shut-off valves and grub screws
- 3 blow the exchanger with compressed air
- 4 dry the exchanger with hot air; for greater safety, fill the exchanger with glycol solution
- 5 protect the exchanger from air
- 6 take the drain caps off the pumps

Any anti-freeze liquid contained in the system should not be discharged freely as it is a pollutant. It must be collected and reused.

Before start-up, wash the system.

It is recommended to have a qualified technician start the system after a period of inactivity, especially after seasonal stops

or for seasonal switch-overs.

When starting, follow the instructions in the “start-up” section.

Schedule technical assistance in advance to avoid hitches and to guarantee that the system can be used when required.

Compressor casing heater

Check:

- closure
- Operation

water side heat exchanger

The exchanger must be able to provide the maximum thermal exchange, therefore it is essential for the inner surfaces to be clean of dirt and build-up.

Periodically check the difference between the temperature of the supply water and the condensation temperature: if the difference is greater than 8°C–10°C it is advisable to clean the exchanger.

The clearing must be effected:

- with circulation opposite to the usual one
- with a speed at least 1,5 times higher than the nominal one
- with an appropriate product moderately acid (95% water + 5% phosphoric acid)
- after the cleaning rinse with water to inhibit the action of any residual product

Water filter

Check that no impurities prevent the correct passage of water.

Flow switch

- controls the operations
- remove incrustations from the palette

safety valve

The pressure relief valve must be replaced :

- if it has intervened
- if there is oxidation
- based on the date of manufacture, in compliance with local regulations.

circulation pumps

Check:

- no leaks
- Bearing status (anomalies are highlighted by abnormal noise and vibration)
- The closing of terminal covers and the correct positioning of the cable glands.

Insulations

Check the condition of the insulations: if necessary, apply glue and renew the seals.

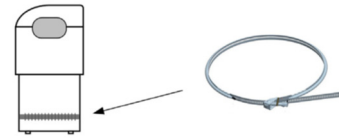

Air coil

Accidental contact with the exchanger fins can cause cuts: wear protective gloves.

The coil must allow maximum thermal exchange, therefore, the surface must be clear from dirt and scaling.

Remove all impurities from the surface.

As an alternative, vacuum cleaner can be used to suck impurities from the air input side.

Check the aluminium flaps have not been damaged or folded, on the contrary contact an authorised after-sales assistance centre to "comb" the coil for excellent air flow.

Disconnection

WARNING

⇒ Before performing any operation, read the warnings found in the Maintenance chapter.

Avoid leak or spills into the environment.

Before disconnecting the unit, the following must be recovered, if present:

- refrigerant gas
- Anti-freeze solutions in the hydraulic circuit

Awaiting decommissioning and disposal, the unit can also be stored outdoors, as bad weather and rapid changes in temperature do not harm the environment provided that the electric, cooling and hydraulic circuits of the unit are intact and closed.

WEEE INFORMATION

The manufacturer is registered on the EEE National Register, in compliance with implementation of Directive 2012/19/EU and relevant national regulations on waste electrical and electronic equipment.

This Directive requires electrical and electronic equipment to be disposed of properly.

Equipment bearing the crossed-out wheelie bin mark must be disposed of separately at the end of its life cycle to prevent damage to human health and to the environment.

Electrical and electronic equipment must be disposed of together with all of its parts.

To dispose of “household” electrical and electronic equipment, the manufacturer recommends you contact an authorised dealer or an authorised ecological area.

“Professional” electrical and electronic equipment must be disposed of by authorised personnel through established waste disposal authorities around the country.

In this regard, here is the definition of household WEEE and professional WEEE:

WEEE from private households: WEEE originating from private households and WEEE which comes from commercial, industrial, institutional and other sources which, because of its nature and quantity, is similar to that from private households. Subject to the nature and quantity, where the waste from EEE was likely to have been by both a private household and users of other than private households, it will be classed as private household WEEE;

Professional WEEE: all WEEE which comes from users other than private households.

This equipment may contain:

refrigerant gas, the entire contents of which must be recovered in suitable containers by specialised personnel with the necessary qualifications;

- lubrication oil contained in compressors and in the cooling circuit to be collected;
- mixtures with antifreeze in the water circuit, the contents of which are to be collected;
- mechanical and electrical parts to be separated and disposed of as authorised.

When machine components to be replaced for maintenance purposes are removed or when the entire unit reaches the end of its life and needs to be removed from the installation, waste should be separated by its nature and disposed of by authorised personnel at existing collection centres.



Warning:
Fire hazard
Flammable materials



FOR OVER 30 YEARS, WE HAVE BEEN
OFFERING SOLUTIONS TO ENSURE
SUSTAINABLE COMFORT
AND THE WELL-BEING OF PEOPLE
AND THE ENVIRONMENT



sales and assistance

www.clivet.com



CLIVET SPA

Via Camp Lonc 25, Z.I. Villapaiera

32032 Feltre (BL) - Italy

Tel. +39 0439 3131 - Fax +39 0439 313300

info@clivet.it

A Group Company of

